

Yale

HOISTING EQUIPMENT



Hoisting Equipment

Yale and Pfaff-silberblau hoisting equipment products are reliable and proven equipment renowned world-wide for applications in industry, trade and services.

The comprehensive range includes manual and powered hoisting equipment for a safe lifting and handling of loads ranging from 125kg to 20000kg. The products feature a long service life as well as easy and quick maintenance or repair.

Yale and Pfaff-silberblau hoisting equipment products comply with national and international regulations such as the EC Machinery Directive 2006/42/EC and corresponding supplements. In order to meet our high quality standard, the devices are subjected to an overload test in the factory and provided with a test certificate and operating instructions with a declaration of conformity or a manufacturer's declaration.

INFO

Please note our user instructions at the beginning of each chapter.

Table of contents

	Page
Ratchet lever hoists	14 - 21
Hand chain hoists	22 - 35
Corrosion protection	36
Trolleys & Trolley clamps	35, 37 - 43
Electric & Pneumatic chain hoists	48 - 65
Chains & Accessories	66 - 68
Manual winches	69 - 79
Cable puller & Accessories	80 - 87
Electric & Pneumatic winches	91 - 107
Rack & Pinion jacks	108 - 123
Crane Systems	128 - 139
Power supply	140 - 141

Hand chain hoist model Yalelift 360

Capacity 500 - 20000 kg

Areas of operation as well as operator conditions have been improved far beyond those of a classical hand chain hoist.

Features

- The enclosed robust stamped steel housing protects all internal components even in the toughest conditions.
- The extremely low headroom allows maximum use of the lifting height.
- The revolutionary 360° rotating hand chain guide allows the operator to work from virtually any position, in confined spaces or above the load. The Yalelift can even be operated from the side of the load which also makes it possible to use the hoist for horizontal pulling or tensioning. Due to the additional flexibility, the operator is no longer forced to work in the danger zone near the load.
- The brake system is extremely quiet and guarantees operational safety and improved serviceability due to omission of the vulnerable ratchet pawls. All parts are made of high quality materials, additionally zinc-plated or yellow-chromated to increase corrosion prevention.
- Chain guide and gearbox are almost totally enclosed. Even under the toughest conditions the internal gearbox remains protected.
- The hardened load sheave with four precision machined pockets ensures accurate movement of the load chain.
- The surface protected zinc-plated alloy steel load chains fulfil all requirements of current national and international standards and regulations.
- Drop forged load and suspension hooks that yield under overload instead of breaking, are made of high tensile steel. The hooks are fitted with robust safety latches and rotate 360°.

Options

- Adjustable overload protection device.
- Chain container
- Corrosion resistant version



*Patented!
Rotating hand
chain guide*



Available in explosion proof version (please see page 448).

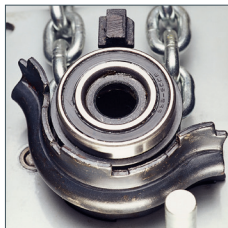

Chain guide



High quality encapsulated ball bearings and sliding bushes for smooth and effortless operation.

INFO

Easy modification from Yalelift 360 to Yalelift IT is possible.

Yale hoists and trolleys are not designed for passenger elevation applications and must not be used for this purpose.

Hand chain hoist model Yalelift 360 20t

Capacity 20000kg

The brake system used in the Yalelift series is also employed in the Yalelift 360 20t, setting standards in terms of operational safety and serviceability. The brake is extremely quiet and wear resistant. In spite of its high capacity, the Yalelift 360 20t features a compact design.

Features

- All components are made of high quality materials, some components are zinc-plated or yellow-chromated for added corrosion protection. This ensures that also heaviest loads are held reliably.
- The enclosed robust stamped steel body resists in the toughest conditions and allows outside operation.
- The hardened load sheave with five precision machined pockets ensures accurate movement of the load chain.
- The low headroom (hook-to-hook dimension 1010 mm) allows maximum use of the lifting height.
- The Yalelift 360 20t is equipped with six chain falls only which results in higher speed and lower weight.

Options

- Adjustable overload protection device.
- Chain container
- Corrosion resistant version

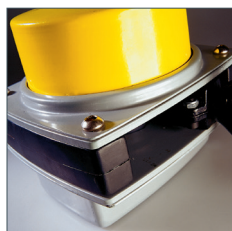

The robust stamped steel housing with four stay bolts is resistant to the toughest working conditions.



The precisely machined load sheave ensures accurate movement of the load chain.



Technical data model Yalelift

Model	EAN-No. 4025092*	Capacity kg	Number of chain falls	Chain dimensions d x p mm	Lift per 1 m hand chain overhaul mm	Pull on hand chain at WLL daN	Weight at standard lift (3 m) kg
YL 500	*288545	500	1	5x15	33	21	9
YL 1000	*288552	1000	1	6x18	20	30	13
YL 2000	*288569	2000	1	8x24	14	32	20
YL 3000	*941129	3000	1	10x30	12	38	29
YL 5000	*941143	5000	2	10x30	6	34	38
YL 10000	*291842	10000	3	10x30	4	44	71
YL 20000	*292153	20000	6	10x30	2	2x44	196



Dimensions model Yalelift

Model	YL 500	YL 1000	YL 2000	YL 3000	YL 5000	YL 10000	YL 20000
A min., mm	300	335	395	520	654	825	1065
B, mm	17	22	30	38	45	68	85
C, mm	24	29	35	40	47	68	64
D, mm	133	156	182	220	220	220	303
E, mm	148	175	203	250	250	383	555
F, mm	148	167	194	219	219	219	250
G, mm	139	164	192	225	242	326	391
H, mm	206	242	283	335	352	436	501
I, mm	24	24	31	34	21	136	-
K, mm	61	70	83	95	95	95	396
L, mm	87	97	111	124	124	124	125
M, mm	110	125	156	178	285	401	471
N, mm	14	19	22	30	37	50	56

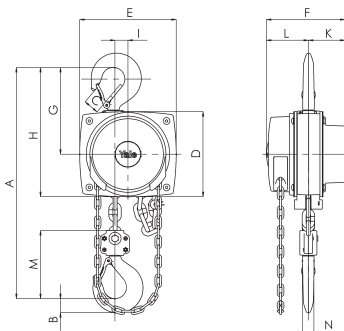

Model Yalelift 360, 500 - 3000kg, single fall

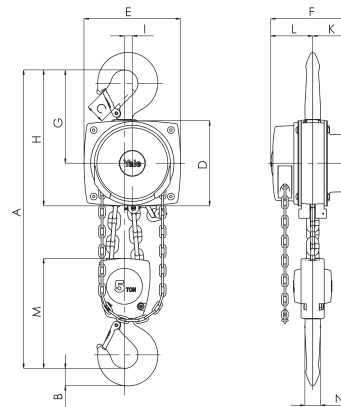

Model Yalelift 360, 5000kg, double fall

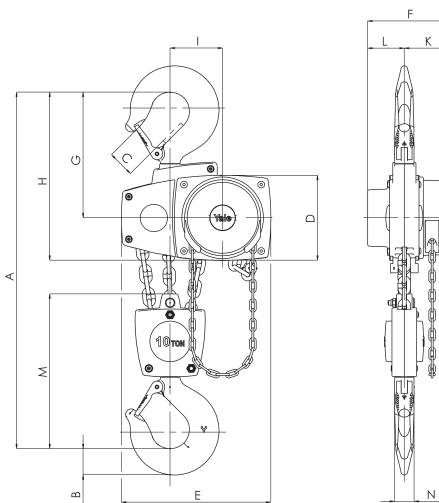

Model Yalelift 360, 10000kg, three fall

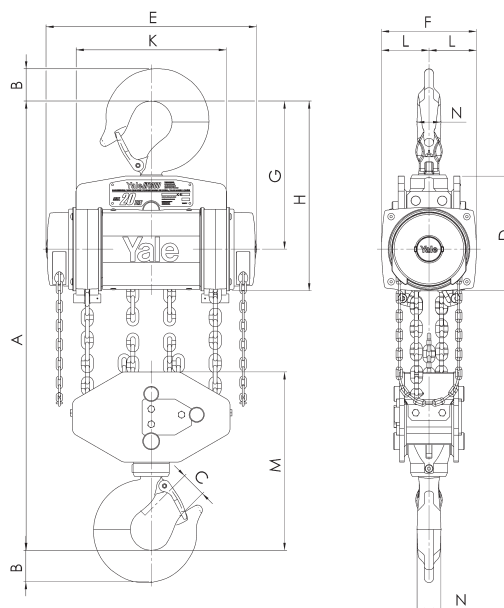

Model Yalelift 360, 20000kg, six fall



Hand chain hoist model VSIII

Capacity 250 - 5000 kg

The newly designed hand chain hoist VSIII is an innovative further development introduced by Yale. The improved hand chain guide prevents canting or jamming of the hand chain, leading to a smooth running of the chain. High quality bearings on side plates, gearbox and load chain sheave ensure smooth operation of load chain and drive pinion. Optimized hand forces set standards for easy operation.

Features

- Strong bolts between side plates and housing cover and the reinforced hand wheel cover ensure increased stability.
- Precision machined guide rollers ensure smooth running of the load chain.
- High quality bearings for gearbox, side plates and load chain sheave permit a long service life.
- Zinc-plated and yellow-chromated brake parts and guide rollers ensure increased corrosion protection.
- Zinc-plated load chain as standard for added corrosion protection.

Options

- Overload protection device
- Chain container



Load chain sheave with needle bearing

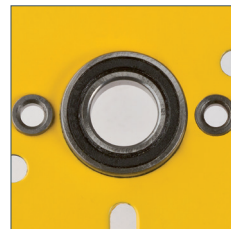

Side plate with ball bearing

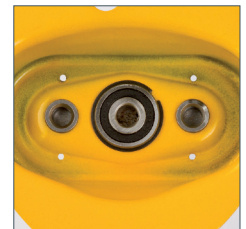

Housing cover with ball bearing

Technical data model VSIII

Model	EAN-No. 4025092*	Capacity in kg/ number of chain falls	Chain dimensions d x p mm	Lift per 1 m hand chain overhaul mm	Pull on hand chain at WLL daN	Weight at standard lift (3 m) kg
VSIII 0,25/1	*665322	250/1	4x12	50	20	3.9
VSIII 0,5/1	*949545	500/1	5x15	26	21	9.0
VSIII 1,0/1	*949927	1000/1	6x18	24	24	11.5
VSIII 1,5/1	*593854	1500/1	8x24	17	30	17.5
VSIII 2,0/1	*949934	2000/1	8x24	19	32	19.0
VSIII 2,0/2	*949941	2000/2	6x18	15	29	17.3
VSIII 3,0/1	*949958	3000/1	10x30	12	40	31.0
VSIII 3,0/2	*949965	3000/2	8x24	10	37	27.0
VSIII 5,0/2	*949972	5000/2	10x30	8	41	43.0

Dimensions model VSIII

Model	VSIII 0,25/1	VSIII 0,5/1	VSIII 1,0/1	VSIII 1,5/1	VSIII 2,0/1	VSIII 2,0/2	VSIII 3,0/1	VSIII 3,0/2	VSIII 5,0/2
A min., mm	290	350	380	450	460	490	570	580	700
B, mm	12	21	27	33	37	37	46	46	56
C, mm	26	28	32	37	41	41	44	44	50
D, mm	11	16	19	22	27	27	31	31	37
E, mm	118	145	158	180	205	170	240	220	250
F, mm	113	140	155	175	180	155	210	175	190
G, mm	65	80	87	85	94	87	110	94	95
H, mm	48	60	68	90	86	68	100	81	95
K, mm	190	240	270	300	320	285	370	340	410

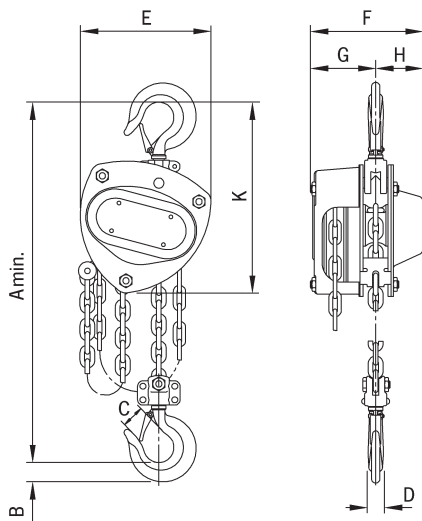

Model VSIII, 250 - 3000 kg, single fall

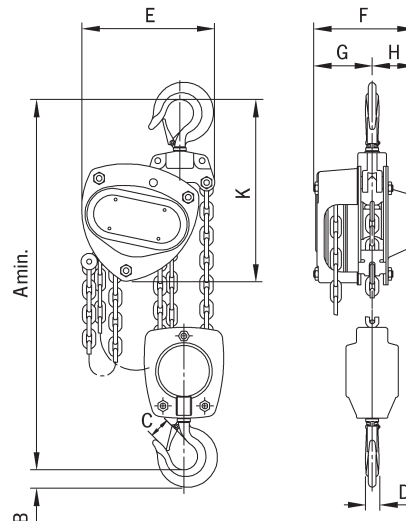

Model VSIII, 2000 - 5000 kg, double fall



Option: Chain container

INFO

Yale hoists and trolleys are not designed for passenger elevation applications and must not be used for this purpose.



Depicted rubber buffers are available optionally.



Available in explosion proof version (please see page 452).

Hand chain hoist with integrated push or geared type trolley model Yalelift IT

Capacity 500 - 20000 kg

The combination of the Yalelift 360 with a low headroom manual trolley provides even more flexibility in the application of the Yalelift 360.

Features

- All units of this series up to a capacity of 3000 kg are provided with single chain fall and the min. headroom (Dim. A) has been further reduced. Ideal for applications with low ceilings and limited headroom.
- The proven and almost stepless adjustment system allows quick and easy assembly of the trolley.
- Trolleys up to 5t are offered for two beam ranges. Range A for a flange width up to 180 mm is standard and covers approx. 80% of all applications. Conversion to range B for beam width up to 300 mm can be easily accomplished.
- The trolley wheels are designed for a max. beam profile incline of 14% (DIN 1025 - part 1), excellent rolling features are guaranteed by prelubricated, encapsulated ball bearings.
- Anti-drop and anti-tilt devices as standard.

Options

- Adjustable overload protection device.
- Chain container
- Rubber buffers
- Corrosion resistant version
- Beam locking device to secure the unloaded trolley in a fixed position on the beam (park position e.g. on ships). Available up to a capacity of 5000 kg.

Technical data model Yalelift ITP/G

Model	EAN-No. 4025092*	Capacity in kg/ number of chain falls	Size	Beam flange width b mm	Beam flange thickness t max. mm	Curve radius min. m	Weight at standard lift (3m) - P kg	Weight at standard lift (3m) - G kg	Weight at standard lift (3m) with locking device - P kg	Weight at standard lift (3m) with locking device - G kg
YLIT 500	*288255	500/1	A	50 - 180	19	0.9	20	24	26	31
YLIT 500	-	500/1	B	180 - 300	19	0.9	21	25	27	32
YLIT 1000	*292221	1000/1	A	50 - 180	19	0.9	27	32	35	40
YLIT 1000	-	1000/1	B	180 - 300	19	0.9	29	33	37	41
YLIT 2000	*291798	2000/1	A	58 - 180	19	1.15	44	49	52	57
YLIT 2000	-	2000/1	B	180 - 300	19	1.15	46	50	54	58
YLIT 3000	*291804	3000/1	A	74 - 180	27	1.5	77	82	86	91
YLIT 3000	-	3000/1	B	180 - 300	27	1.4	79	84	88	93
YLIT 5000	*291828	5000/2	A	98 - 180	27	2.0	125	130	135	140
YLIT 5000	-	5000/2	B	180 - 300	27	1.8	129	134	139	144
YLIT 10000	*080996	10000/3	B	125 - 310	40	1.8	-	202	-	212
YLIT 20000 ¹	*172325	20000/6	B	180 - 310	40	9.5	-	on request	-	on request

¹Dimensions on request

P in connection with weight = with push trolley G in connection with weight = with geared trolley



Chain guide



High quality encapsulated ball bearings and sliding bushes for smooth and effortless operation.



The robust stamped steel housing with four stay bolts is resistant to the toughest working conditions.



The precisely machined load sheave ensures accurate movement of the load chain.

INFO

Yale hoists and trolleys are not designed for passenger elevation applications and must not be used for this purpose.

Hoisting Equipment Hand chain hoists

Dimensions model Yalelift IT

Model	YLIT 500	YLIT 1000	YLIT 2000	YLIT 3000	YLIT 5000	YLIT 10000
A min., mm	245	272	323	382	550	784
A1, mm	158	178	205.5	252	260.5	380
A2, mm	-	-	-	-	-	-
B, mm	17	22	30	38	45	68
C, mm	24	29	35	40	47	68
D, mm	14	19	22	30	37	50
F (Geared trolley), mm	92	92	91	107	149.5	113
H1, mm	24.5	24	23.5	32	30.5	55
I (Push trolley), mm	71.5	71.5	95.5	131	142.5	169
I (Geared trolley), mm	76.5	76.5	98	132.5	148.5	169
L, mm	270	310	360	445	525	430
L1, mm	130	130	150	180	209	200
L2, mm	159	175	207	256	283	261
L3, mm	-	-	-	-	-	-
L4, mm	-	-	-	-	-	-
M, mm	M 18	M 22	M 27	M 30	M 42	M 48
O, mm	60	60	80	112	125	150
P (Geared trolley), mm	108	110	112	112	117	158
T (Area A), mm	280	290	305	320	364	-
T (Area B), mm	400	410	425	440	484	540

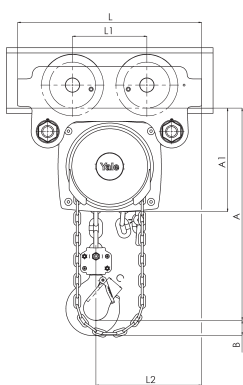

Model Yalelift ITP, 500 - 3000kg, single fall

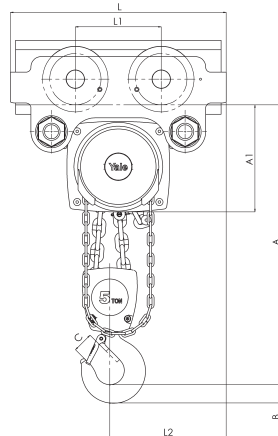
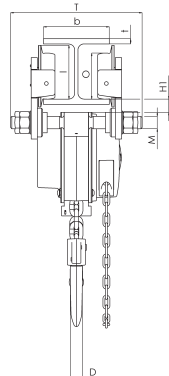

Model Yalelift ITP/ITG, 5000kg, double fall

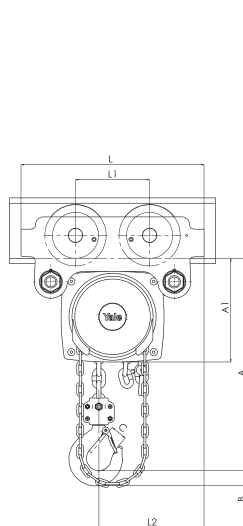
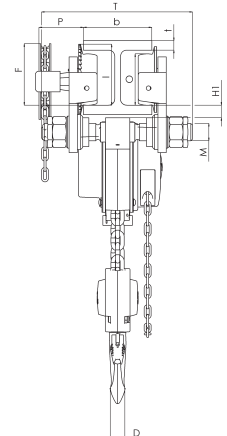
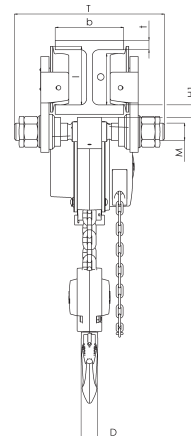

Model Yalelift ITG, 500 - 3000kg, single fall

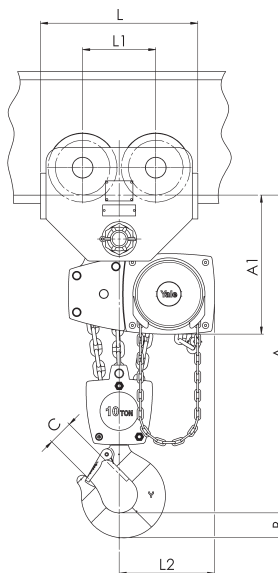
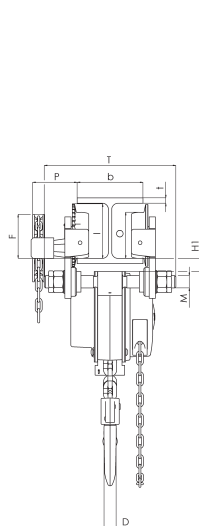

Model Yalelift ITG, 10000kg, three fall

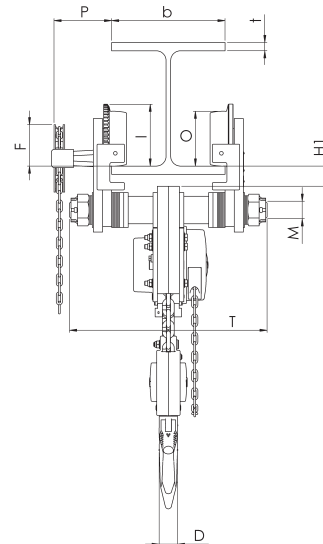

Hand chain hoist with integrated push or geared type trolley (low headroom) model Yalelift LH

Capacity 500 - 10000 kg

The hand chain hoist model Yalelift LH with integrated low headroom manual trolley is the consequent further development of the Yalelift IT. Wherever an even smaller headroom is essential, the Yalelift LH is the ideal choice.

Features

- The specially developed chain reeving system and chain guide allow the bottom block to be pulled laterally to the hoist even further up and almost against the beam flange.
- The integrated design of the innovative Yalelift LH uses the same manual trolleys as incorporated in the Yalelift IT series.
- All models of the LH series up to 3000kg capacity are provided with single chain fall.
- The proven and almost stepless adjustment system allows quick and easy assembly of the trolley.
- The trolleys up to 5t are offered for two beam ranges. Range A for a flange width up to 180mm is standard and covers approx. 80% of all requirements. Conversion to range B for beam width up to 300mm can be easily accomplished.
- The trolley wheels are designed for a max. beam profile incline of 14% (DIN 1025 - part 1), excellent rolling features are guaranteed by prelubricated, encapsulated ball bearings.
- The low headroom version of the Yalelift IT is adjustable to fit a wide range of beam profiles (e.g. INP, IPE, IPB).
- Anti-drop and anti-tilt devices as standard.
- Excellent rolling features due to machined steel wheels mounted on pre-lubricated, encapsulated ball bearings.

Options

- Adjustable overload protection device.
- Chain container
- Corrosion resistant version.
- Beam locking device to secure the unloaded trolley in a fixed position on the beam (park position e.g. on ships).



Available in explosion proof version (please see page 456).

Technical data model Yalelift LH

Model	EAN-No. 4025092*	Capacity in kg/ number of chain falls	Size	Beam flange width b	Beam flange thickness t max.	Curve radius min.	Weight at standard lift (3m) - P	Weight at standard lift (3m) - G	Weight at standard lift (3m) with locking device - P kg	Weight at standard lift (3m) with locking device - G kg
				mm	mm	m	kg	kg		
YLLH 500	*293082	500/1	A	60 - 180	19	0.9	27	31	33	38
YLLH 500	-	500/1	B	180 - 300	19	0.9	27	32	34	38
YLLH 1000	*293167	1000/1	A	70 - 180	19	0.9	35	40	43	48
YLLH 1000	-	1000/1	B	180 - 300	19	0.9	36	41	44	49
YLLH 2000	*319676	2000/1	A	82 - 180	19	1.15	61	65	69	73
YLLH 2000	-	2000/1	B	180 - 300	19	1.15	62	67	70	75
YLLH 3000	*319669	3000/1	A	100 - 180	19	1.5	107	112	116	121
YLLH 3000	-	3000/1	B	180 - 300	19	1.4	109	114	118	123
YLLH 5000	*319652	5000/2	A	110 - 180	27	2.0	152	157	162	167
YLLH 5000	-	5000/2	B	180 - 300	27	1.8	156	161	166	171
YLLH 10000	-	10000/3	A	125 - 210	40	1.8	224	230	234	239
YLLH 10000	-	10000/3	B	190 - 310	40	1.8	227	232	237	242

P in connection with weight = with push trolley
G in connection with weight = with geared trolley

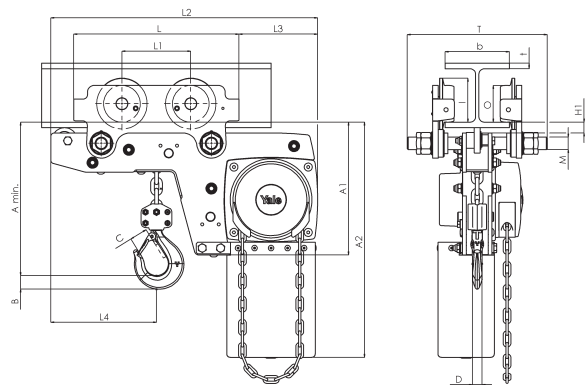

Model Yalelift LHP, 500 - 3000kg, single fall

INFO

Yale hoists and trolleys are not designed for passenger elevation applications and must not be used for this purpose.

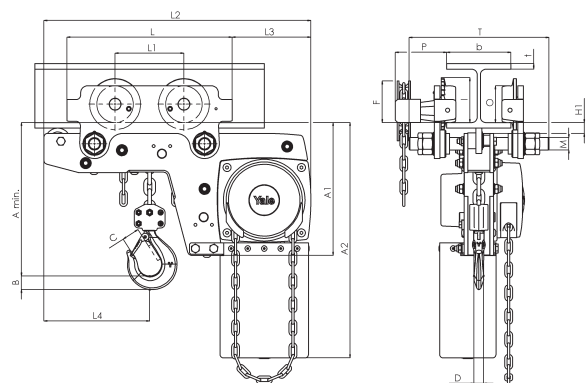

Model Yalelift LHG, 500 - 3000kg, single fall

Dimensions model Yalelift LH

Model	YLLH 500	YLLH 1000	YLLH 2000	YLLH 3000	YLLH 5000	YLLH 10000
A min., mm	188	211	264	316	425	565
A1, mm	223	250	289	346	345	365
A2, mm	381	427	511	614	612	665
B, mm	17	22	30	38	45	68
C, mm	24	29	35	40	47	68
D, mm	14	19	22	30	37	50
F (Geared trolley), mm	92	92	91	107	150	150
H1, mm	24	24	24	32	31	45
I (Push trolley), mm	72	72	96	131	143	170
I (Geared trolley), mm	77	77	98	133	149	170
L, mm	270	310	360	445	525	485
L1, mm	130	130	150	180	209	225
L2, mm	444	488	582	690	720	805
L3, mm	124	135	172	203	175	215
L4, mm	184	201	230	265	283	348
M, mm	M 18	M 22	M 27	M 30	M 42	M 48
O, mm	60	60	80	112	125	150
P (Geared trolley), mm	108	110	112	112	117	165
T (Area A), mm	280	290	305	320	364	440
T (Area B), mm	400	410	425	440	484	540

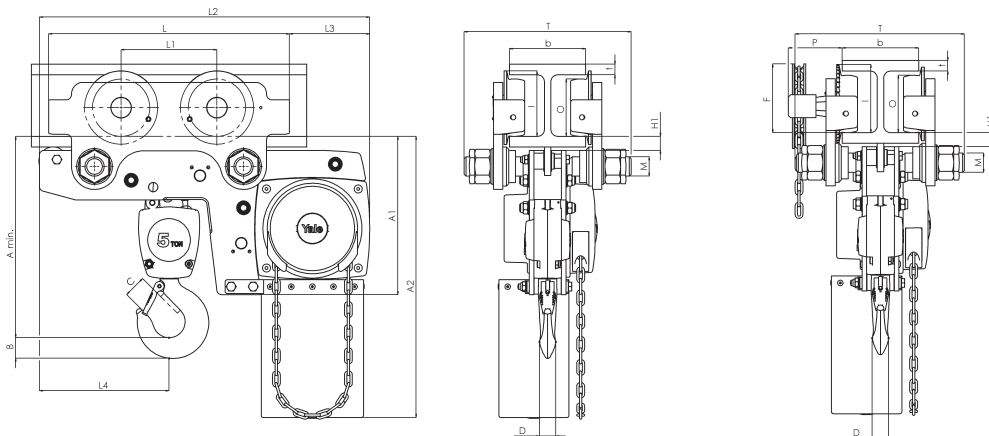

Model Yalelift LHP/LHG, 5000kg, double fall

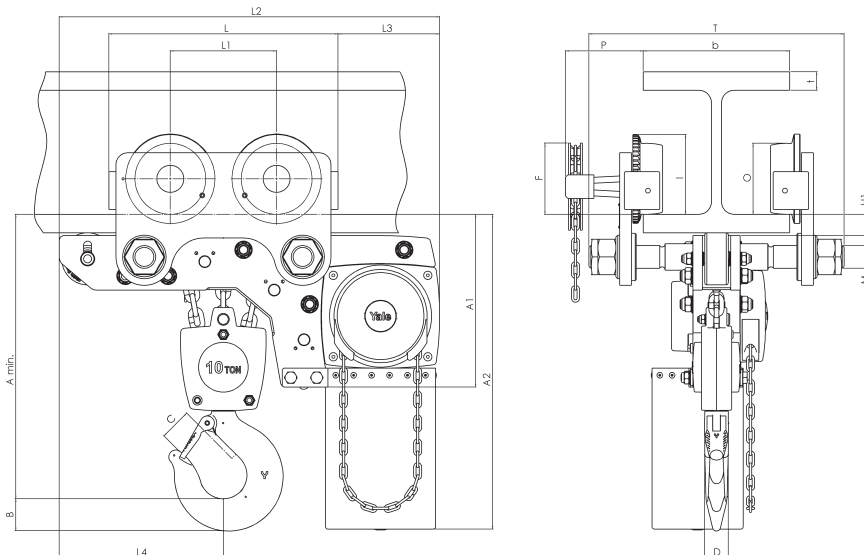

Model Yalelift LHG, 10000kg, three fall



Swivel truck low headroom trolley hoist suitable for extreme curve radius model VLRP and model VLRG

Capacity 250 - 6000 kg

The hand chain hoist series VLR with integrated manual trolley drive features extremely low headroom capabilities and provides optimal usage of the available storage space in confined areas.

Hand wheel and gear case are positioned outside the reach of the bottom flange, thus allowing the bottom block to be raised almost until the underside of the beam. The swivel truck feature of the trolley suspension enables travelling on extremely short radius curves.

Features

- All-steel construction with zinc-plated load and hand chains.
- The integrated swivel truck trolley suspension permits application on runways with extremely narrow radii.
- All units are built to order for a predetermined beam dimension. They cannot be adjusted retro-actively to other beam sizes.
- Anti-drop and anti-tilt devices as standard.
- The rotating hand chain guide allows side-pull of the trolley hand chain in travel direction.

Options

- Overload protection device
- Chain container
- Buffers

INFO

Yale hoists and trolleys are not designed for passenger elevation applications and must not be used for this purpose.

Beam profile and dimension as well as curve radius must always be specified when ordering.

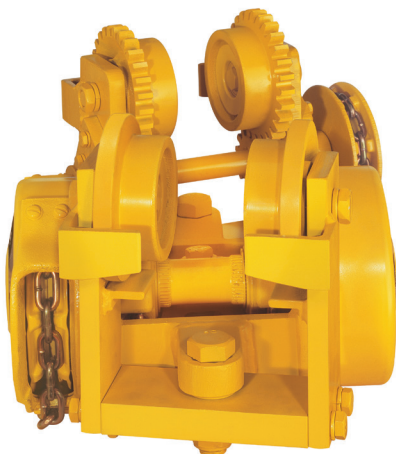

Compact low headroom trolley hoist with integrated manual trolley model VNRP and model VNRG

Capacity 1500 - 24000kg

On account of a special chain reeving system and corresponding chain guide the trolley hoist series VNR offers minimum headroom and maximum usage of the available room height. These hoists have been specially designed for heavy industrial applications.

Features

- All-steel construction with zinc-plated load and hand chains.
- All units are built to order for a predetermined beam dimension. They cannot be adjusted retro-actively to other beam sizes.
- Anti-drop and anti-tilt devices as standard.

Options

- Chain container
- Buffers

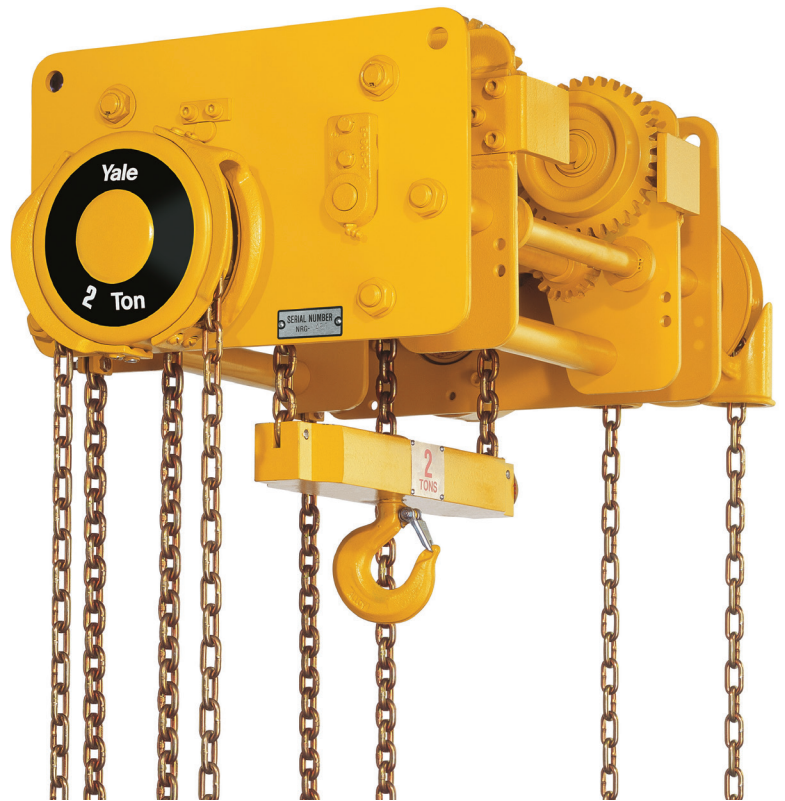

extremely low headroom for confined spaces



Swivel truck trolley with low headroom and extremely short curve radius model VLHP and model VLHG

Capacity 250 - 6000 kg

The manual trolley series VLH features extremely low headroom. The swivel truck construction allows negotiation of very short curve radius.

Features

- All-steel construction with low headroom
- All units are built to order for a predetermined beam dimension. They cannot be adjusted retro-actively to other beam sizes.
- Anti-drop and anti-tilt devices as standard.

Options

- Buffers
- Large variety of special versions.