

# Yale

HOISTING EQUIPMENT



## Hoisting Equipment

Yale and Pfaff-silberblau hoisting equipment products are reliable and proven equipment renowned world-wide for applications in industry, trade and services.

The comprehensive range includes manual and powered hoisting equipment for a safe lifting and handling of loads ranging from 125kg to 20000kg. The products feature a long service life as well as easy and quick maintenance or repair.

Yale and Pfaff-silberblau hoisting equipment products comply with national and international regulations such as the EC Machinery Directive 2006/42/EC and corresponding supplements. In order to meet our high quality standard, the devices are subjected to an overload test in the factory and provided with a test certificate and operating instructions with a declaration of conformity or a manufacturer's declaration.

## INFO

---

Please note our user instructions at the beginning of each chapter.

## Table of contents

	<b>Page</b>
<b>Ratchet lever hoists</b>	<b>14 - 21</b>
<b>Hand chain hoists</b>	<b>22 - 35</b>
<b>Corrosion protection</b>	<b>36</b>
<b>Trolleys &amp; Trolley clamps</b>	<b>35, 37 - 43</b>
<b>Electric &amp; Pneumatic chain hoists</b>	<b>48 - 65</b>
<b>Chains &amp; Accessories</b>	<b>66 - 68</b>
<b>Manual winches</b>	<b>69 - 79</b>
<b>Cable puller &amp; Accessories</b>	<b>80 - 87</b>
<b>Electric &amp; Pneumatic winches</b>	<b>91 - 107</b>
<b>Rack &amp; Pinion jacks</b>	<b>108 - 123</b>
<b>Crane Systems</b>	<b>128 - 139</b>
<b>Power supply</b>	<b>140 - 141</b>

## Wall-mounted winch model SW-W

### Capacity 80 - 750 kg

Wall-mounted rope winches of the SW-W model range are intended for fixed stationary mounting inside a building. The steel wire rope is guided to the required suspension point of the load by means of deflection sheaves.

#### Features

- Robust aluminium housing for models SW-W 80 and SW-W 125, proven steel plate design for models SW-W 300 - 750.
- Spur gear drive for optimal efficiency and comfortable handling. Direct drive for loads up to 125 kg.
- The low-noise safety spring brake safely holds the load in every position.
- Removable hand crank for models SW-W 80 and SW-W 125, foldable crank for models SW-W 300 - 750.
- Easy and quick mounting onto walls.



### Technical data model SW-W

Model	EAN-No. 4025092*	Capacity 1 <sup>st</sup> layer kg	Capacity top layer kg	Drum diameter mm	Rope diameter mm	Useable rope length 1 <sup>st</sup> layer m	Useable rope length top layer m	Lift per crank rotation mm	Required crank effort daN	Weight without rope kg
SW-W 80	*984638	80	45	51	3 <sup>1</sup>	2.4	30	170	12	3
SW-W 125	*686235	125	65	40	4 <sup>1</sup>	2	12	138	13	3
SW-W 300	*990509	300	220	108	5 <sup>2</sup>	2.1	15	68	15	10
SW-W 500	*984669	500	350	108	6 <sup>2</sup>	2.4	15	35	13	11
SW-W 750	*984508	750	550	108	7 <sup>2</sup>	2	10	35	20	11

<sup>1</sup>recommended rope: DIN 3055 FE-znk 1770 sZ-spa

<sup>2</sup>recommended rope: DIN 3060 FE-znk 1770 sZ-spa

### Dimensions model SW-W

Model	SW-W 80	SW-W 125	SW-W 300	SW-W 500	SW-W 750
EAN-No.	*984638	*686235	*990509	*984669	*984508
A, mm	110	110	250	250	250
B, mm	110	110	250	250	250
C, mm	130	130	290	290	290
D, mm	130	130	290	290	290
Ø E, mm	9	9	14.5	14.5	14.5
F, mm	15	15	2	2	2
H, mm	121	121	85	85	85
I, mm	55	55	138	138	138
J, mm	-	-	117	117	117
K, mm	250	250	250	250	250
L, mm	130	130	130	130	130
M, mm	68	68	39	39	39
O, mm	60	60	50	50	50
P, mm	275	275	192	192	192

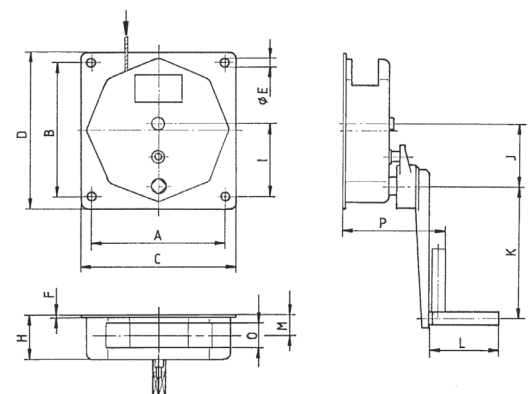



## Wall-mounted winch model SW-W ALPHA

**Capacity 300 - 1000 kg**

A versatile wall-mounted winch for an easy lifting of loads.

### Features

- Light weight robust stamped steel housing and compact design.
- Spur gear drive for optimal efficiency and comfortable handling.
- Rope lead-offs to all directions.
- All parts are zinc-plated for increased corrosion protection, drum with additional special coating.
- Integrated crank with load pressure brake for safe holding of the load.
- Easy and quick mounting onto walls.

## INFO

For a better guiding of the rope to the suspension point we recommend the use of sheaves or sheave blocks, please see page 79.

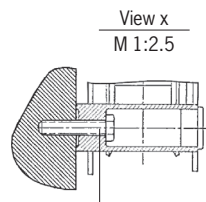

Fastening screws to be fastened with M12 bolts quality class 8.8 (not included)

## Technical data model SW-W ALPHA

Model	EAN-No. 4050939***	Capacity 1 <sup>st</sup> layer kg	Capacity top layer kg	Drum length mm	Rope diameter mm	Useable rope length 1 <sup>st</sup> layer m	Useable rope length top layer m	Lift per crank rotation mm	Required crank effort daN	Weight without rope kg
<b>SW-W ALPHA 300</b>	***050917	300	130	50	5 <sup>2</sup>	1.3	28	57	13	10
<b>SW-W ALPHA 500</b>	***051037	500	230	50	6 <sup>2</sup>	1	20	55	17	10
<b>SW-W ALPHA 750</b>	***051181	750	270	50	7 <sup>2</sup>	1	26	45	17	16
<b>SW-W ALPHA</b>	***051228	1000	360	50	7 <sup>2</sup>	1	26	45	18	16

<sup>2</sup>recommended rope: DIN 3060 FE-znk 1770 sZ-spa

## Dimensions model SW-W ALPHA

Model	SW-W ALPHA 300	SW-W ALPHA 500	SW-W ALPHA 750	SW-W ALPHA 1000
Art.-No.	***050917	***051037	***051181	***051228
A, mm	234	234	306	306
B, mm	262	262	337	337
C, mm	274	274	357	357
D, mm	203	203	265	265
E, mm	107	107	107	107
F, mm	194	194	194	194
G, mm	183	183	255	255
Ø H, mm	63	63	63.5	63.5
I, mm	200	250	250	320
J, mm	58.6	58.6	92.5	92.5
K, mm	109.5	109.5	107	107

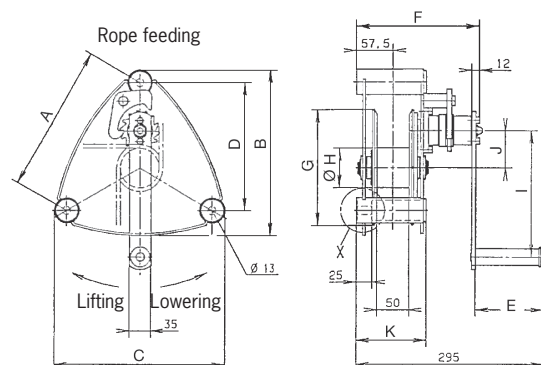

## Wall-mounted winch with worm gear drive model SW-W-SGO

### Capacity 250 - 5000 kg

Wall-mounted winch with worm gear drive and load pressure brake for efficient lifting of heavy loads.

#### Features

- Housing and rope drums made out of robust steel plate.
- Worm gear drive with additional load pressure brake for safe holding of the load.
- Roller bearings ensure smooth running of the rope and increased lifetime of the winch.
- Second speed for fast lifting of smaller loads, resulting in lowest possible handle effort and rapid winding of the rope (for capacities of 2000kg and above).
- Wide rope drum for a large rope capacity with two rope attachment points.
- Easy and quick mounting.



Model SW-W-SGO  
Capacity 1500 kg

### Technical data model SW-W-SGO

Model	EAN-No. 4050939***	Capacity 1 <sup>st</sup> layer kg	Capacity top layer kg	Rope diameter mm	Useable rope length 1 <sup>st</sup> layer m	Useable rope length top layer m	Lift per crank rotation mm	Required crank effort daN	Weight without rope kg
SGO 250	***049263	250	100	5 <sup>2</sup>	2.3	44	29	6	13
SGO 500	***049270	500	238	6 <sup>2</sup>	3.7	54	30	11	16
SGO 1000	***051464	1000	500	9 <sup>2</sup>	4.5	46	21	10,6	26
SGO 1500	***051563	1500	850	10 <sup>2</sup>	4.5	38	18	16	28
SGO 2000	***050443	2000	1100	13 <sup>2</sup>	4	37	8/16 <sup>3</sup>	9/18 <sup>3</sup>	60
SGO 3000	***050481	3000	2000	16 <sup>2</sup>	5	34.5	7/14 <sup>3</sup>	12/24 <sup>3</sup>	78
SGO 5000	***050818	5000	3300	20 <sup>2</sup>	4.5	33.8	8/16 <sup>3</sup>	25.2/50.4 <sup>3</sup>	105

<sup>2</sup>recommended rope: DIN 3060 FE-znk 1770 sZ-spa    <sup>3</sup>1<sup>st</sup>/2<sup>nd</sup> speed

### Dimensions model SW-W-SGO

Model	SGO 250	SGO 500	SGO 1000	SGO 1500	SGO 2000	SGO 3000	SGO 5000
EAN-No.	***049263	***049270	***051464	***051563	***050443	***050481	***050818
A, mm	238	269	302	302	410	436	436
B, mm	145	160	195	250	310	365	460
C, mm	100	115	141	178	196	251	316
D, mm	192	223	254	254	360	386	386
G, mm	106	107	110	111	137	137	137
H, mm	102	131	160	160	176	204	200
Ø J, mm	48	70	102	102	133	165	219
Ø K, mm	14	14	17	17	25	25	25
Ø L, mm	160	190	240	240	312	376	437
M, mm	191	221	266	278	383	443	495
N, mm	15	15	15	15	45	47	60
O, mm	354	384	429	441	-	-	-
P, mm	280	325	350	350	380	380	380
R, mm	171	192	264	306	420	527	604
S, mm	130	130	130	130	220	220	220

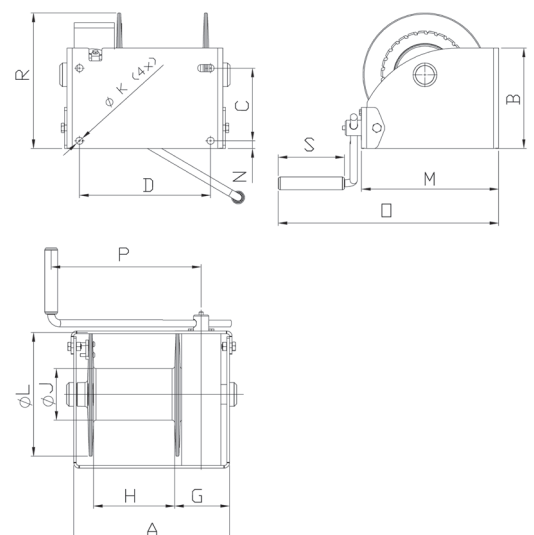



### Manual winch with spur gear drive model MWS

#### Capacity 150 - 1500 kg

For the operation where no electricity is available or in a dirty environment.

Recommended rope diameter according to DIN 3060 FE-znk 1770 sZ-spa.

#### Features

- Enclosed gear drive for protection of internal parts, even under tough working conditions.
- Spur gears on roller bearings, rope drum on plain bearings.
- Compact design.
- Easy and quick mounting onto walls, poles etc.
- They have a self-locking, anti-kickback and adjustable crank handle for fast lifting of smaller loads, resulting in lowest possible handle effort and rapid winding of the rope.
- Automatic load pressure brake for safe holding and extremely sensitive lowering of the load. Unintentional brake release is prevented even with swinging loads.
- They are suitable for operation in ambient temperatures of -20°C up to +40°C.

#### Option

- Corrosion resistant version.

## INFO

---

For a better guiding of the rope to the suspension point we recommend the use of sheaves or sheave blocks, please see page 79.

Pfaff winches are not designed for passenger elevation applications and must not be used for this purpose.

## Technical data model MWS

Model	EAN-No. 4025092* 4053981**	Capacity 1 <sup>st</sup> layer kg	Capacity top layer kg	Crank effort 1 <sup>st</sup> layer daN	Lift per crank rotation 1 <sup>st</sup> layer mm	Lift per crank rotation top layer mm	Weight without rope kg	Rope diameter mm	Useable rope length 1 <sup>st</sup> layer m	Useable rope length max. m	Number of layers max.
<b>MWS 150</b>	*635356	150	68	11	122	210	4	4 <sup>2</sup>	0.8	13	8
<b>MWS 300</b>	*635363	300	166	6	32	44	10	5 <sup>2</sup>	1.8	21	7
<b>MWS 600</b>	*635370	600	308	10	28	41	11	6 <sup>2</sup>	1.2	12	6
<b>MWS 1000</b>	**790718	1000	587	11	20	27	27	9 <sup>2</sup>	3.0	25	5
<b>MWS 1500</b>	**790732	1500	844	12	14	19	27.5	10 <sup>2</sup>	2.7	21	5

<sup>2</sup>recommended rope: DIN 3060 FE-znk 1770 sZ-spa

## Dimensions model MWS

Model	MWS 150	MWS 300	MWS 600	MWS 1000	MWS 1500
A, mm	65	200	200	219	219
B, mm	168	300	300	250	250
C, mm	128	268	268	212	212
D, mm	40	168	168	150	150
E, mm	303	318	318	484	484
F, mm	-	-	-	250	250
G, mm	26	-	-	30	30
H, mm	41	55	55	113	113
I, mm	-	-	-	170	170
Ø J, mm	35	70	60	102	102
K, mm	9	12	12	17	17
Ø L, mm	102	145	145	212	212
M, mm	168	182	182	130	130
N, mm	89	199	199	338	338
O, mm	92	96	96	44	44
P, mm	-	-	-	104	104
Q, mm	-	-	-	190	190
S, mm	129	129	129	129	129

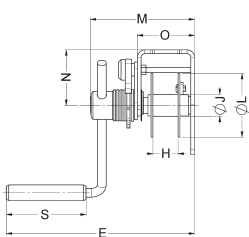

Model MWS, capacity 150 kg

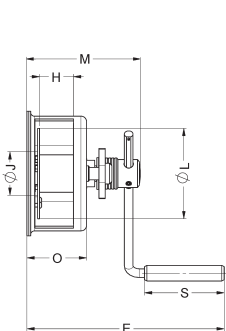
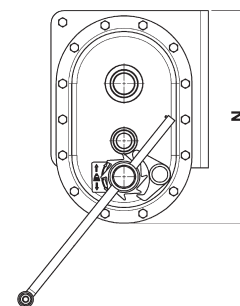
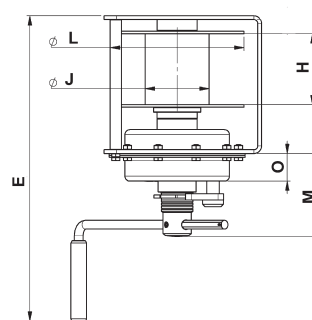
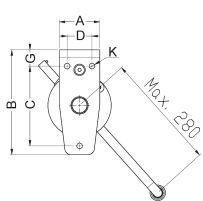

Model MWS, capacity 300 - 600 kg

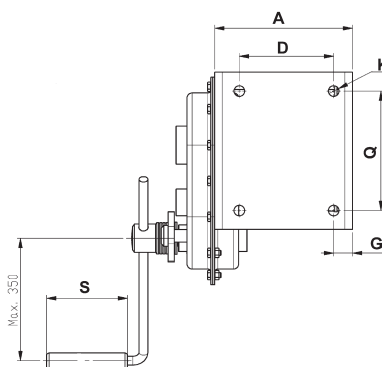
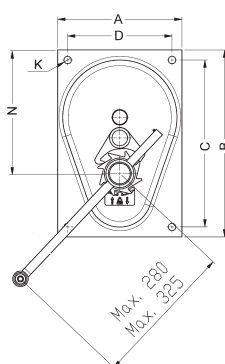

Model MWS, capacity 1000 - 1500 kg

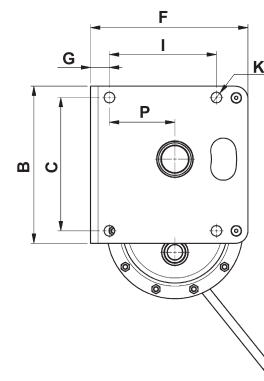



Model LB,  
zinc-plated version,  
capacity 1200 kg



Model LB,  
zinc-plated version,  
capacity 350 kg

## Console-mounted winch model LB

### Capacity 150 - 1200 kg

Originally developed as offroad winch the console-mounted winch model LB is used today for a variety of lifting and pulling applications.

#### Features

- Light weight robust stamped steel housing.
- Spur gear drive for optimal efficiency and comfortable handling.
- Automatic load pressure brake for safe holding of the load in any position. An unintentional brake release is prevented.
- All parts are zinc-plated for increased corrosion protection, drum with additional special coating.
- Easy and quick mounting to consoles, even under lifting conditions.

#### Options

- Stainless steel version (mat. 1.4301) for increased corrosion protection.
- Free wheeling device for a quick manual unrolling of the unloaded rope.



Model LB-VA,  
stainless steel version,  
capacity 900 kg



## Technical data model LB

Model	EAN-No. 4025092* 4050939*** Zinc-plated version	EAN-No. 4025092* 4050939*** Free wheeling device	EAN-No. 4025092* 4050939*** Stainless steel version	Capacity 1 <sup>st</sup> layer kg	Capacity top layer kg	Rope diameter mm	Useable rope length 1 <sup>st</sup> layer m	Useable rope length top layer m	Lift per crank rotation mm	Required crank effort daN	Weight without rope kg
<b>LB 150 VZ</b>	***050542	-	-	150	75	4 <sup>2</sup>	0.8	11	125	17	4.2
<b>LB 350 VZ</b>	***050559	-	-	350	170	4 <sup>2</sup>	1.8	20	125	25	4.8
<b>LB 650 VZ</b>	*994736	-	-	650	290	6 <sup>2</sup>	1	20	55	22	7.3
<b>LB 900 VZ/ARA</b>	*994859	*992251	-	900	400	7 <sup>2</sup>	0.8	14	58	24	10
<b>LB 1200 VZ/ LB 250 VA</b>	*561655	***049249	-	1200	430	7 <sup>3</sup>	1	26	45	24	12.1
<b>LB 250 VA</b>	-	-	*441964	250	125	4 <sup>2</sup>	1.8	19.5	125	20	4.8
<b>LB 650 VA</b>	-	-	*284875	650	290	6 <sup>2</sup>	1	20	55	22	7.6
<b>LB 900 VA</b>	-	-	*562461	900	320	7 <sup>2</sup>	1	26	45	24	12.1

<sup>2</sup>recommended rope: DIN 3060 FE-znk 1770 sZ-spa    <sup>3</sup>recommended rope: DIN 3069 SE-znk 2160 sZ-spa

## Dimensions model LB

Model	LB 150 VZ	LB 350 VZ	LB 650 VZ	LB 900 VZ LB 900 ARA	LB 1200 VZ LB 1200 ARA	LB 250 VA	LB 650 VA	LB 900 VA
EAN-No. Zinc-plated version	***050542	***050559	*994736	*994859	*561655	-	-	-
EAN-No. Free wheeling device	-	-	-	*992251	***049249	-	-	-
EAN-No. Stainless steel version	-	-	-	-	-	*441964	*284875	*562461
A, mm	-	-	232	232	273	-	232	273
B, mm	155	155	192	192	266	155	192	266
C, mm	175	175	210	210	240	175	210	240
Ø D, mm	36	36	63.5	63.5	63.5	36	63.5	63.5
Ø E, mm	100	100	183	183	255	100	183	255
F, mm	-	-	100	100	78	-	100	78
G, mm	75	75	58	58	75	75	58	75
H, mm	-	-	100	100	138	-	100	138
K, mm	159	189	192	192/226*	192/226*	191.5	190	190
L, mm	-	-	25	25	35	-	25	35
M, mm	45	75	38	38	30	75	38	30
N, mm	-	-	-	-	53	-	-	53
O, mm	200	320	250	320	320	320	250	250
P, mm	260	290	293	293/303*	293/303*	292.5	291	291
Q, mm	81	111	95	95	95	111	95	95
R, mm	50	80	50	50	50	80	50	50
S, mm	48	63	55	55	55	65.5	55	55

\*Free wheeling device

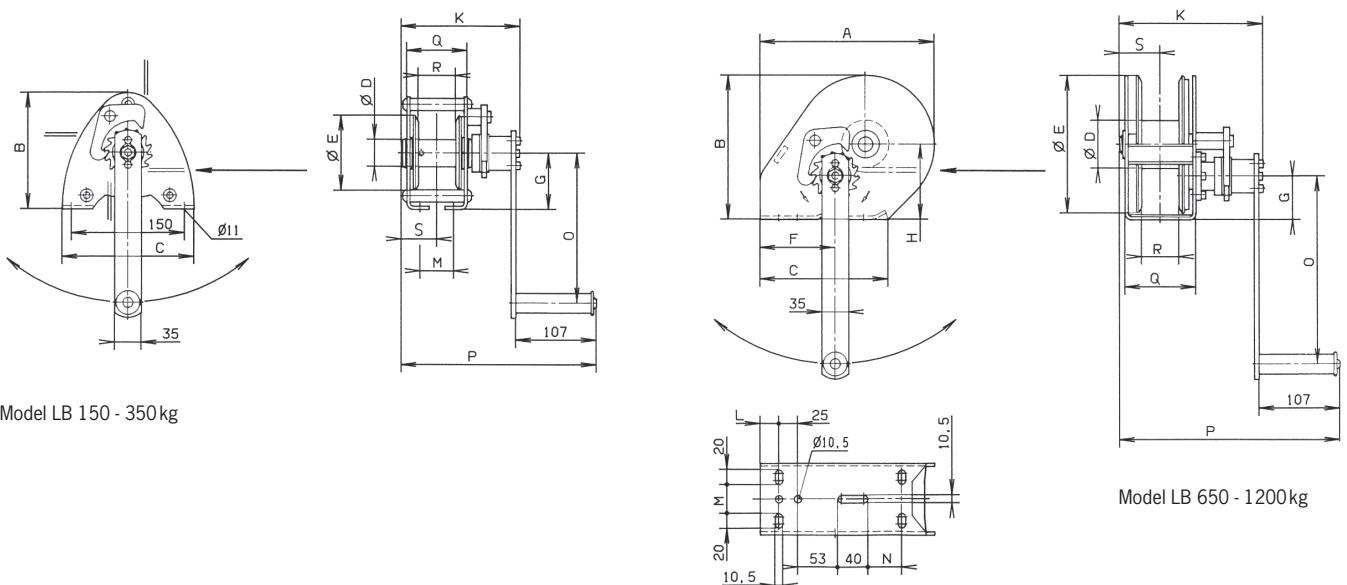

Model LB 150 - 350 kg

Model LB 650 - 1200 kg



Model SW-K GAMMA  
capacity 800 kg



Model SW-K GAMMA  
capacity 500 kg

## Console-mounted aluminium rope winch model SW-K GAMMA

### Capacity 200 - 800 kg

Due to its rugged design, the aluminium rope winch is suitable for operation outdoors.

### Features

- Compact aluminium housing and enclosed sprocket wheel drive. From a capacity of 500 kg with speed increasing ratio for small loads and quicker winding and unwinding of the unloaded rope.
- Spur gear drive for optimal efficiency and comfortable handling.
- Enclosed gear for the protection of parts inside, also for arduous applications.
- Low-friction shaft sliding bearings for improved rope lead-off and a longer service life of the winch.
- Wide rope drum for a large rope capacity with two rope attachment points.
- Easy and quick mounting.
- With integrated safety spring brake system and removable crank. The winches can be operated from either side.

## Technical data model SW-K GAMMA

Model	EAN-No. 4025092*	Capacity 1 <sup>st</sup> layer kg	Capacity top layer kg	Rope diameter mm	Useable rope length 1 <sup>st</sup> layer m	Useable rope length top layer m	Lift per crank rotation mm	Required crank effort daN	Ratio	Weight without rope kg
<b>GAMMA 200</b>	*984690	200	110	4 <sup>2</sup>	3.6	40	195	19	–	6
<b>GAMMA 500</b>	*983808	500	200	6 <sup>2</sup>	4.2	50	60/400 <sup>3</sup>	12	6.57:1	14

<sup>2</sup>recommended rope: DIN 3060 FE-znk 1770 sZ-spa

<sup>3</sup>load/speed increasing ratio

## Dimensions model SW-K GAMMA

Model	GAMMA 200	GAMMA 500	GAMMA 800
EAN-No.	*984690	*983808	*441346
A, mm	120	120	200
B, mm	160	220	326
C, mm	192	330	336
D, mm	152	100	180
E, mm	165	267	327
F, mm	135	125	250
Ø G, mm	9.5	11	14
Ø H, mm	50	60	70
L, mm	320	250	320
M, mm	207	165	207

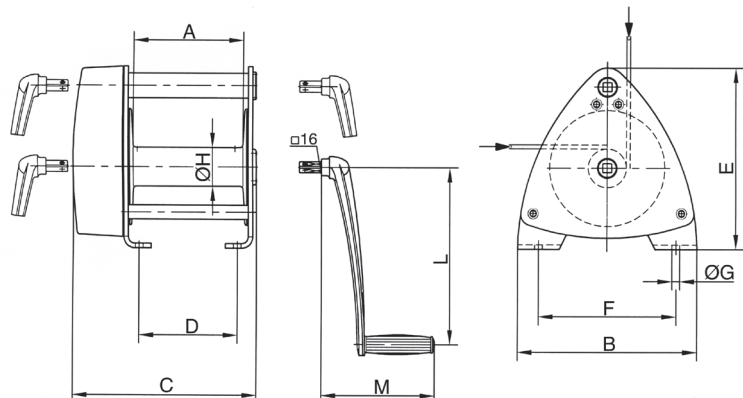

## Compact aluminium rope winch with free-wheeling device model SW-KAL

### Capacity 750 - 1120 kg

Console-mounted rope winches are used for super-structures on vehicles and trailers and when lifting and lowering loads.

#### Features

- Self-locking worm gear, free-wheeling device for ease of operation.
- Enclosed gear for the protection of internal parts, also for arduous applications.
- Low-friction shaft bearings for a longer service life of the winch.
- Easy and quick mounting.



## INFO

Pfaff winches are not designed for passenger elevation applications and must not be used for this purpose.

### Technical data model SW-KAL

Model	EAN-No. 4050939***	Capacity 1 <sup>st</sup> layer kg	Capacity top layer kg	Drum diameter mm	Rope diameter mm	Useable rope length 1 <sup>st</sup> layer m	Useable rope length max. m	Lift per crank rotation mm	Lift per crank rotation top layer mm	Required crank effort daN	Weight without rope kg
<b>KAL 750</b>	***051242	750	600	100	6 <sup>2</sup>	1.3	10	15	17	20	7
<b>KAL 1120</b>	***051389	1120	600	63	7 <sup>2</sup>	0.5	10	11	16	22	7

<sup>2</sup>recommended rope: DIN 3060 SE-znk 1770 sZ-spa

### Dimensions model SW-KAL

Model	KAL 750	KAL 1120
Art.-No.	030207004	030208000
A, mm	165	165
B, mm	168	168
C, mm	170	170
Ø D, mm	100	63
E, mm	180	180
F, mm	135	135
G, mm	60	60
H, mm	56	50
J, mm	160	160
Ø K, mm	13	13
L, mm	85	85

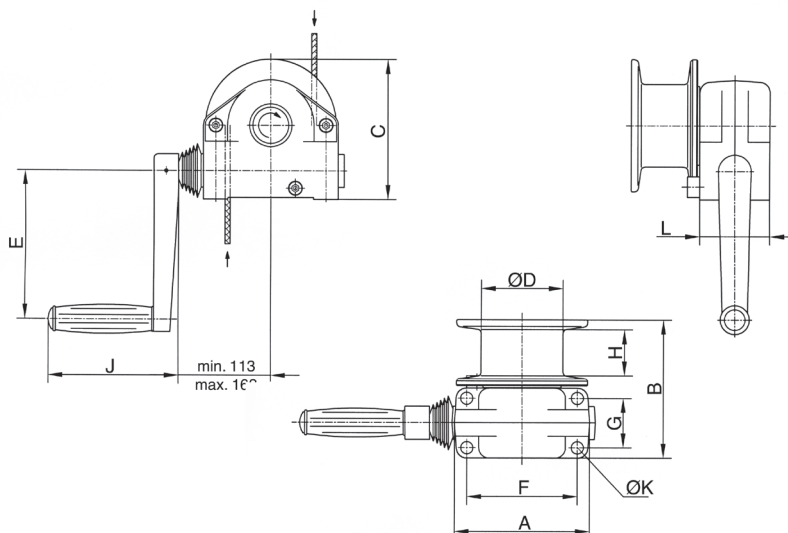

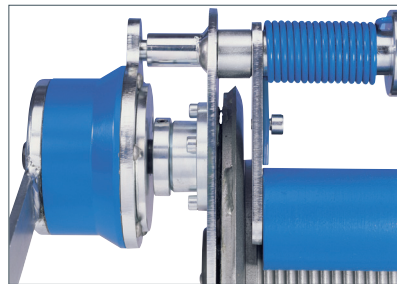
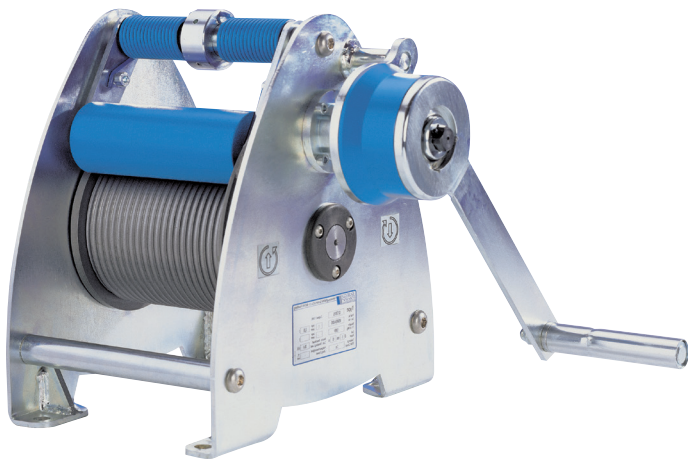

## Console-mounted rope winch model SW-K LAMBDA (DGUV Vorschrift 17 [BGVC1])

### Capacity 300 kg

The compact rope winch for applications on stages, in studios, theatres, etc.

### Features

- State-of-the-art design with galvanized side sections for easy handling.
- Grooved drum for single-layer winding of the steel rope. An 18:1 ratio between drum and rope diameter increases the service life of the rope substantially.
- With spring-loaded rope pressure roller to prevent the unloaded rope from jumping off the drum.
- Gear rated for twice the nominal load.
- Spur gear drive for optimal efficiency and comfortable handling.
- The fitted safety crank with two spring brakes acting independently of each other for safe holding of the load in any position.
- Complies with DGUV Vorschrift 17 (BGVC1) and DIN 56925-1.

### Options

- Drum extension for a larger rope capacity.
- Special grooves (several layers)

## INFO

Certified by the German committee for lifting equipment (GS-approval-tested safety).

## Technical data model SW-K LAMBDA (DGUV Vorschrift 17 [BGVC1])

Model	EAN-No. 4050939***	Capacity kg	Rope diameter mm	Useable rope length max. 1 <sup>st</sup> layer m	Lift per crank rotation mm	Required crank effort daN	Ratio	Weight without rope kg
SW-K LAMBDA	***050382	300	6	10	50	18	8.83:1	30
SW-K LAMBDA	***050405	300	6	15	50	18	8.83:1	36

recommended steel rope: 6 DIN 3069 SE-znk 1960 sZ-spa (breaking load of the rope min. 30.4kN)

## Dimensions model SW-K LAMBDA (DGUV Vorschrift 17 [BGVC1])

EAN-No.	***050382	***050405
A, mm	379	469
B, mm	310	310
C, mm	340	340
Ø D, mm	139.4	139.4
E, mm	180	270
F, mm	280	280
G, mm	175	265
Ø H, mm	13	13
J, mm	250	250
K, mm	130	130

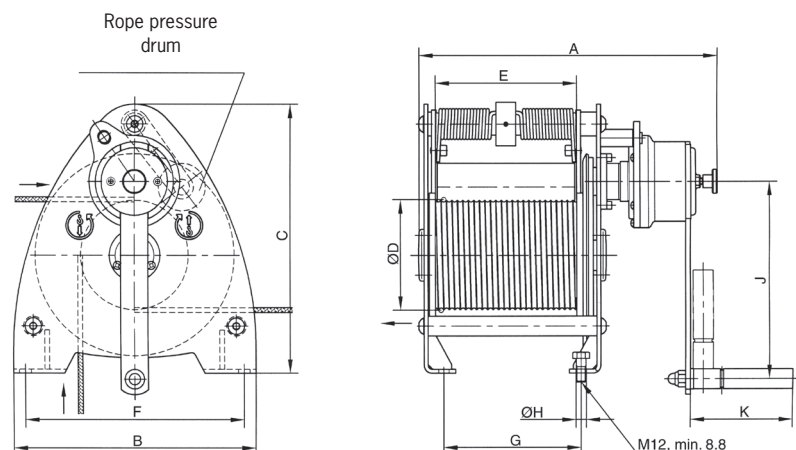

## Sheave block for rope guidance, equipped with ball bearings model DSRB S

### Technical data model DSRB

Model	EAN-No. 4025092* 4050939***	Classification  FEM/ISO	Pulling force in kg at deflection 90°	Pulling force in kg at deflection 180°	Rope diameter  mm
DSRB S 90/4	***066062	2m/M5	700	500	3-4
DSRB S 90/6	***066123	1Dm/M1	700	500	5-6
DSRB S 145/7	*990424	1Am/M4	1100	800	7
DSRB S 185/8	***065843	2m/M5	2300	1630	8
DSRB S 270/12	***065980	2m/M5	2500	1800	9-12
DSRB S 400/16	***066130	3m/M6	5000	3800	13-16
DSRB S 490/20	***065751	3m/M6	8000	6000	20

All sheaves are available as an individual component on request.

### Dimensions model DSRB

Model	DSRB S 90/4	DSRB S 90/6	DSRB S 145/7	DSRB S 185/8	DSRB S 270/12	DSRB S 400/16	DSRB S 490/20
EAN-No.	***066062	***066123	*990424	***065843	***065980	***066130	***065751
B, mm	85	85	125	138	191	302	313
C, mm	90	90	160	195	290	430	580
Ø D, mm	90	90	145	185	270	400	490
Ø D1, mm	20	25	25	30	40	50	65
Ø Dm, mm	80	78	126	160	246	368	450
E, mm	62	62	88	106	138	212	220
H, mm	134	134	224	273	407	612	694
K, mm	65	65	110	135	202	310	340
L, mm	120	120	200	245	360	530	650
Ø M/M1, mm	9/9	9/9	11.5/13	13.5/15	18/20	26/30	34/40
S, mm	4	6	6	8	10	15	16

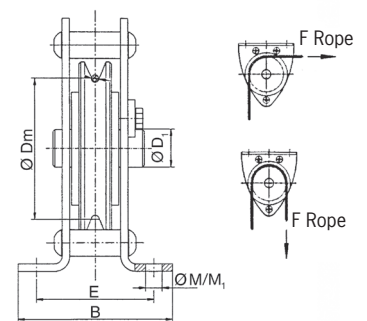
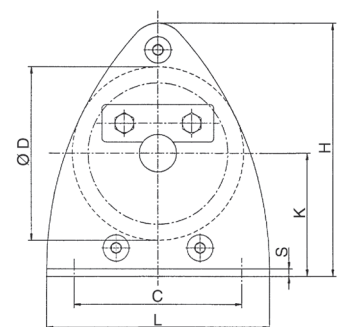

Available in explosion proof version (please see page 465).

## Standard ropes for Pfaff-silberblau manual winches

According to DIN 3060

### EAN-order number

Rope diameter	Breaking load of rope min. kN	Useable rope length 5m	Useable rope length 10m	Useable rope length 15m	Useable rope length 20m	Capacity clevis end kg
4 mm - DIN 3060	10.1	4050939 050924	4050939 050962	4050939 051075	4050939 051204	500
5 mm - DIN 3060	15.8	4050939 050955	4050939 050993	4050939 051143	4050939 051235	1000
6 mm - DIN 3060	22.8	4050939 050986	4050939 051167	4050939 051266	4050939 051358	1000
7 mm - DIN 3060	31.0	4025092 990585	4050939 051211	4050939 051365	4050939 051549	1000
7 mm - DIN 3069 <sup>1</sup>	43.9	-	-	4050939 051624	-	1600

<sup>1</sup>Rope with increased breaking load for LB 1200 kg

## INFO

Additional accessories available on request.

## Cable puller model Yaletrac ST

### Pulling force 1000 - 3200 daN

Cable pullers model Yaletrac ST feature a housing of dimensionally stable deep-drawn steel plates ensuring a compact, robust design in combination with optimised weight.

The benefits of the previous Yaletrac range have been maintained and supplemented to the needs of the market. The hand operating forces have been noticeably optimised for the user by the application of axial ball bearings.

### Features

- Stable upright positioning of the unit due to the combination of handle and foot.
- Space-saving telescopic hand lever that can be safely attached to the unit by means of a hook-and-pile fastener.
- Increased service life of the unit due to the use of rubber sleeves which prevent dirt and dust from penetrating into the mechanical equipment of the unit.
- Positioning of the forward and reversing levers in tandem provides a slim design and ensures optimal power transfer.
- Overload protection is provided by a shearing pin. Spare shear pins are conveniently located in the carrying handle. A broken pin can be replaced without removing the load.
- A lever disengages the rope clamp system allowing easy and smooth installation of the rope.
- Yaletrac ST uses a special flexible rope. It has six strands with a steel core and is identified by an orange strand. The rope is tapered at one end for easy threading and is fitted with an eye sling hook with safety latch on the other end.
- The parallel arrangement of the clamping system protects the rope by distributing the clamping forces evenly. A long rope advance per each lever stroke increases the working speed.
- The large opening in the top of the unit allows easy cleaning: simply flush the unit with water and apply motor oil for lubrication and the Yaletrac ST is again ready for use.



Option:  
Eye sling hook  
with safety latch



Option:  
Yaletrac storage box made from steel plate,  
approx. 74 x 26 x 45 cm

### Options

- Eye sling hook with safety latch
- Longer ropes
- Drum reel



## Technical data model Yaletrac ST

Model	EAN-No. 4025092*	Capacity WLL kg	Rope advance per double stroke mm	Lever pull at WLL daN	Lever length mm	Rope diameter mm	Weight without rope kg	Rope weight kg/m
Y 10 ST	*422901	1000	60	23	800	8.4	8.5	0.29
Y 16 ST	*422925	1600	60	28	790/1190	11.5	15.8	0.53
Y 32 ST	*422963	3200	40	46	790/1190	16	27.2	1.0

## Dimensions model Yaletrac ST

Model	Y 10 ST	Y 16 ST	Y 32 ST
L, mm	435	560	664
H, mm	178	205	240
H1, mm	235	280	350
B, mm	61	86	96
B1, mm	94	125	123

## INFO

Yale hoists and trolleys are not designed for passenger elevation applications and must not be used for this purpose.

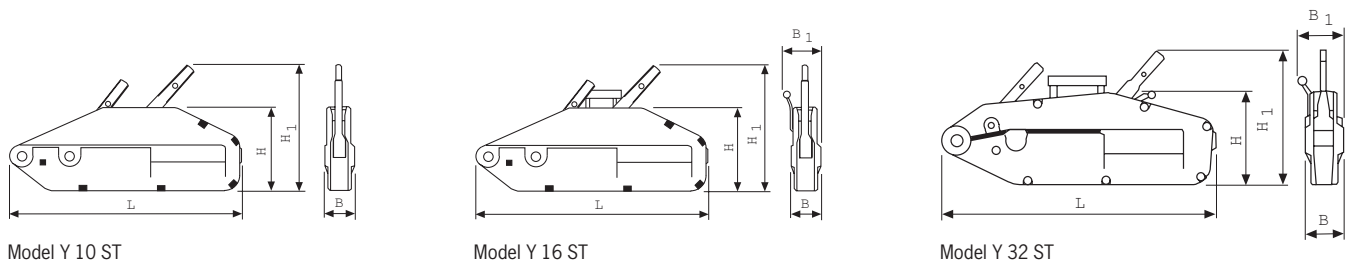

Rubber sleeves prevent dirt from penetrating into the mechanical equipment and thus increase the service life

Rope clamp disengagement lever for easy installation of the rope

Axial ball bearings for optimised hand operating forces

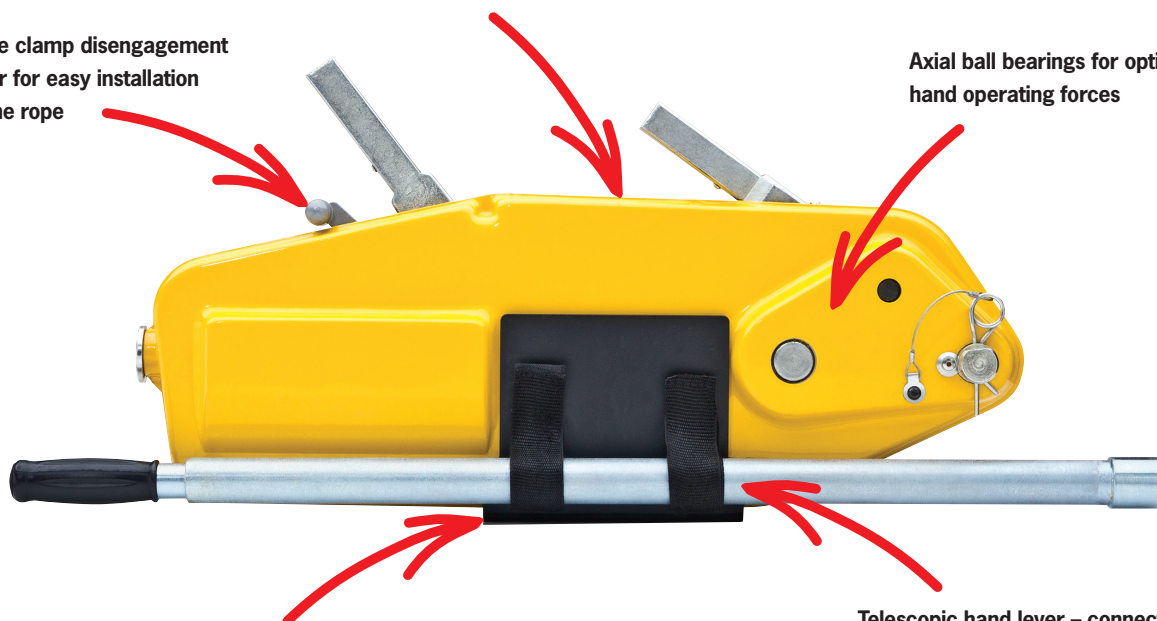

Foot for stable positioning of the unit

Telescopic hand lever – connected to the unit safely for transportation

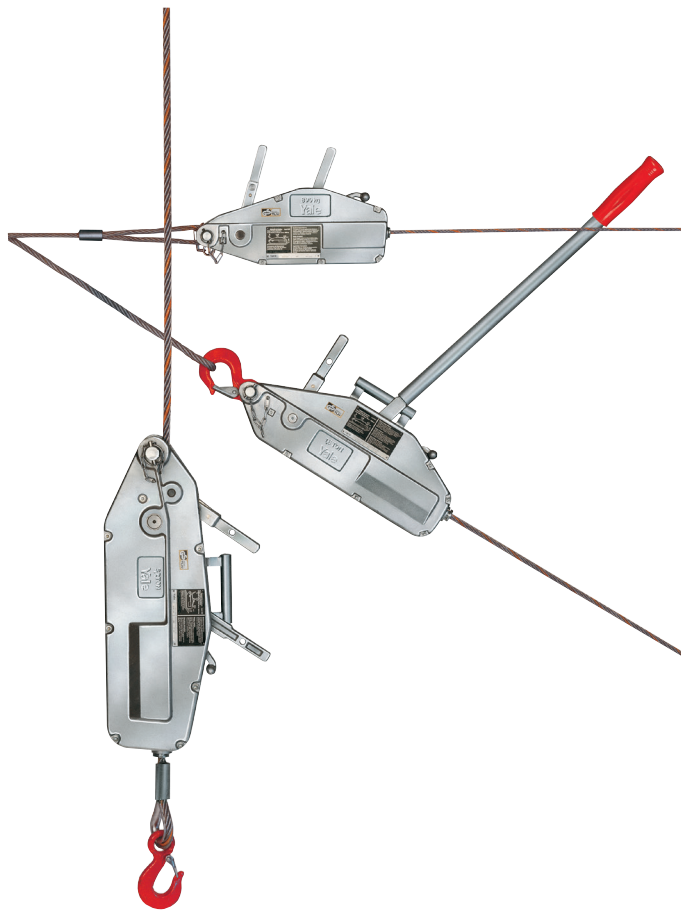

## Cable puller model Yaletrac

### Pulling force 800 - 3200 daN

It has a light weight, compact, high tensile aluminium alloy housing with a large flat bottom surface for increased stability in horizontal as well as vertical working position.

### Features

- Forward and reversing levers in tandem provide slim design and assure power transfer along the centre line.
- Overload protection is by a shearing pin in the forward lever. Spare shear pins are conveniently located in the carrying handle or operating lever. A broken pin can be replaced without removing the load.
- A lever disengages the rope clamp system allowing easy, smooth installation of the rope.
- Yaletrac uses a special flexible rope. It has six strands with a steel core and is identified by an orange strand. The rope is tapered at one end for easy threading and fitted with an eye sling hook with safety latch on the other end.
- The parallel arrangement of the clamping system protects the rope by distributing the clamping forces evenly. A long rope advance per each lever stroke increases the working speed.
- The large opening in the top of the unit allows easy cleaning: simply flush the unit with water, apply motor oil for lubrication and the Yaletrac is again ready for use.

### Options

- Eye sling hook with safety latch
- Longer ropes
- Drum reel
- Storage box

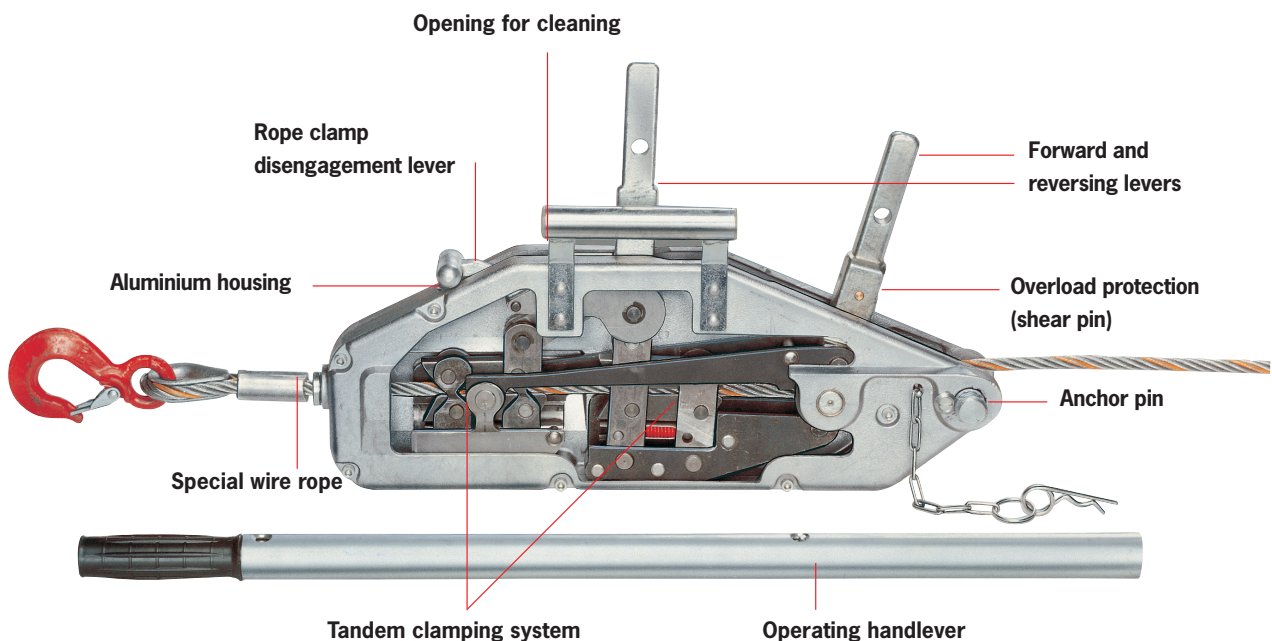



## Technical data model Yaletrac

Model	EAN-No. 4025092*	Capacity WLL kg	Rope advance per double stroke mm	Lever pull at WLL daN	Lever length mm	Rope diameter mm	Weight without rope kg	Rope weight kg/m
Y 08	*051811	800	60	24	800	8.4	7	0.29
Y 16	*051828	1600	60	30	790/1190	11.5	14	0.53
Y 32	*078870	3200	40	50	790/1190	16	21	1

## Dimensions model Yaletrac

Model	Y 08	Y 16	Y 32
L, mm	430	545	680
H, mm	168	190	230
H1, mm	240	270	330
B, mm	60	72	91
B1, mm	-	97	110

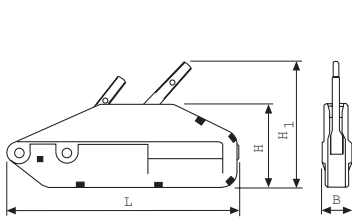

Model Y 08

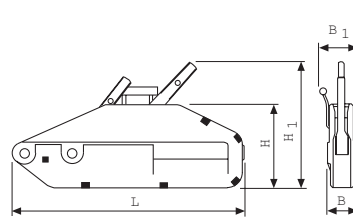

Model Y 16

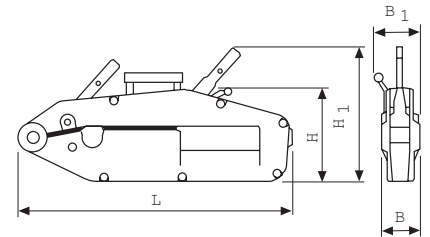

Model Y 32



Option:  
Yaletrac storage box made from steel plate,  
approx. 74x26x45 cm



Option:  
Eye sling hook with safety latch

## INFO

Yale hoists and trolleys are not designed for passenger elevation applications and must not be used for this purpose.

Complementary products available like cable grips (see page 87), pulley blocks (see page 86) and textile slings (see pages 232-235).



## Cable puller model LP

### Capacity 500 kg

A practical aid for pulling, lifting, tensioning and lowering in many applications in- and outdoors.

A compact, handy tool – ideal for service and assembly, for workshops and recreation.

### Features

- The stamped steel housing is lightweight and resistant.
- The complete set comprises of a cable puller with anchor bolt and eye sling hook, telescopic operating lever, 10 metres of wire rope, carrying handle and a webbing sling of 1 metre length which can be used as a rigging point.

## INFO

Yale hoists and trolleys are not designed for passenger elevation applications and must not be used for this purpose.

### Technical data model LP

Model	EAN-No. 4025092*	Capacity WLL kg	Rope advance per double stroke mm	Lever pull at WLL daN	Lever length mm	Rope diameter mm	Weight without rope and lever kg
LP 500	*051804	500	35	15	600	8.3	4

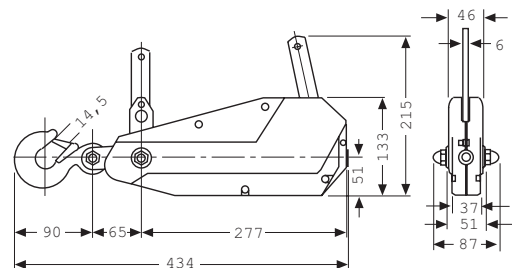

## Cable puller model LM

### Pulling force 500 - 1800 daN

The use of aluminium alloy castings provide a light-weight, corrosion resistant unit for pulling and tensioning applications. The double interlocking pawl system ensures safe function, all load bearing shafts are mounted on prelubricated bearings to reduce wear.

#### Features

- All springs and shafts are manufactured from stainless steel. The lifting medium is a non-twisting, galvanized, special steel wire rope.
- The hooks are fitted with safety latches and are free to rotate 360°.
- The cable puller LM can be used in single or double legged configuration. In double legged configuration the pulling force is doubled and the lifting height is halved.



### Technical data model LM

Model	EAN-No. 4025092*	1 legged design			2 legged design			Weight kg	Lever length mm	Hook opening mm	Rope diameter mm
		pulling force daN	hook path m	headroom mm	pulling force daN	hook path m	headroom mm				
<b>115 DV-B</b>	*077293	500	4.6	550	1000	2.3	700	4.5	420	22	4.8
<b>202 WN-VB</b>	*077309	500	6.0	525	1000	3.0	690	5.2	520	22	4.8
<b>434 WN-VB</b>	*077316	500	9.0	550	1000	4.5	710	5.8	530	22	4.8
<b>S 434 WN-VB</b>	*077491	700	6.0	565	1400	3.0	725	6.0	530	22	5.6
<b>S 404 WN-VB</b>	*077323	900	5.2	575	1800	2.6	720	5.9	635	22	6.4

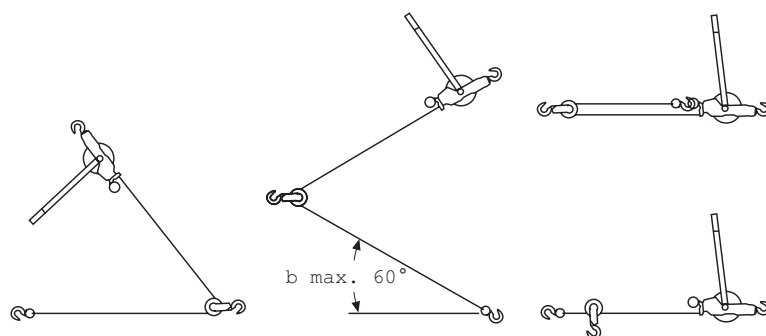

Rigging configurations - Attention! reduced capacity!

### INFO

Yale hoists and trolleys are not designed for passenger elevation applications and must not be used for this purpose.

The units may only be used for pulling and tensioning. Lifting and lowering of loads is not permitted.

## Pulley blocks, hinged, with single steel sheave

### Capacity 1000 - 6400kg

One side of the Yale pulley blocks is hinged and can be opened for easy and quick positioning of the wire rope on the sheave. It can also provide a quick and versatile rigging point or redirect a wire rope.

### Features

- Swinging the hook in the direction of pull securely locks the pulley block.
- The high quality cast steel sheaves have machined grooves and are fitted with Permaglide® bushes.
- When choosing and classifying pulley blocks, take the "Principles for Rope Drives" DIN 15020 into consideration.



### Technical data pulley blocks

Model	EAN-No. 4025092*	Capacity kg	Rope diameter mm	Weight kg
<b>Pulley blocks 1000</b>	*455817	1000	7	3.3
<b>Pulley blocks 2000</b>	*455794	2000	13	8.9
<b>Pulley blocks 3200</b>	*455800	3200	15	15.5
<b>Pulley blocks 6400</b>	*455824	6400	18	26.5

### Dimensions pulley blocks

Model	Kloben 1000	Kloben 2000	Kloben 3200	Kloben 6400
B, mm	118	199	230	270
B1, mm	76	92	108	116
B2, mm	17	24	28	35
C, mm	23	27	31	42
Ø D1, mm	85	150	180	210
Ø D2, mm	105	190	220	260
L, mm	305	425	496	655
L1, mm	200	263	295	375
L2, mm	23	30	40	47
R, mm	4	7	9	10

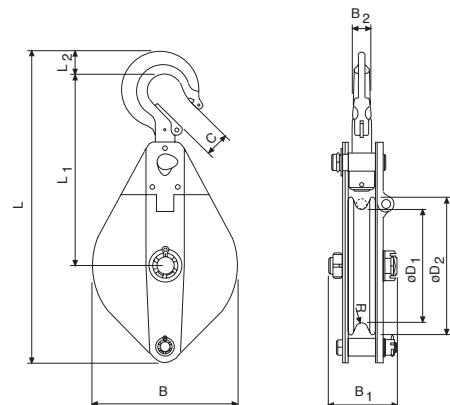

## INFO

Yale hoists and trolleys are not designed for passenger elevation applications and must not be used for this purpose.



## Cable grip model LMG

### Pulling force 2000 - 5000 daN

The LITTLE MULE® cable grip is a device for gripping, pulling and tensioning uncoated wire ropes, cables and metal rods in all forms up to a tensile strength of 1770 N/mm<sup>2</sup> but is dependant on the diameter and surface condition.

The parallel jaws provide a firm, non-slip grip without causing damage to the wire rope. A special spring-loaded guide prevents the grip from dropping off the wire rope and allows instant release without jamming.

The model LMG II-X is supplied with grooved jaws and is suitable for wire ropes with a tensile strength of up to 1960 N/mm<sup>2</sup>, but is dependant on the rope diameter and surface condition.



### Technical data model LMG

Model	EAN-No. 4025092*	Pulling force daN	For rope diameter mm	Eye opening mm	Weight kg
LMG I	*052214	2000	5 - 15	31 x 44	1.6
LMG II	*052221	3000	8 - 20	31 x 44	2.9
LMG II-X	*052245	3000	8 - 20	31 x 44	2.9
LMG III	*052238	5000	18 - 32	66 x 93	9.5

## INFO

Yale hoists and trolleys are not designed for passenger elevation applications and must not be used for this purpose.

## Steel rope for manual and electric winches

All Pfaff-silberblau electric winches are supplied without load bearing mechanisms as standard. To ensure safe operation an optimum rope design, optimum length and associated fastening elements (hooks, shackles) are selected.

We recommend to choose wire ropes on the basis of design, type of construction and strength to suit the intended use and frequency of use. The features of the different types of rope design are as follows:

### Breaking load

→ Load bearing capacity, strength of the rope

### Bending fatigue + flexibility

→ Service life

### External wear

→ Stability of the outer strands

### Torsion characteristics

→ Lifting of guided or unguided loads

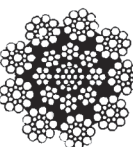
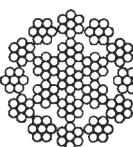
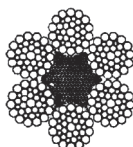
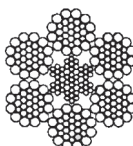
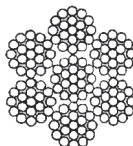
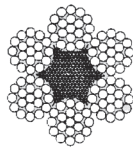

### Handling

Our product range includes winches for lifting, pulling and moving of loads. In combination to our winches the following rope types apply:

#### Standard design

##### 6 x 19 + FE 1770 N/mm<sup>2</sup>

##### Manual winch rope with fiber inlay 3 - 12 mm Ø

Galvanized or stainless steel in mat. 1.4401

Nominal strength 1570 N/mm<sup>2</sup> (low breaking load)

- not non-twisting
- crosslay type of construction
- low-tension
- lifting rope for infrequent actuation
- rugged and widely resistant

#### Warrington-Seale

##### 6 x 36 WS+SES (FE) 1770 N/mm<sup>2</sup>

##### Manual and electric winch rope in parallel type of construction 10 - 28 mm Ø

Galvanized, with fiber or steel inlays as options

- highly flexible
- high breaking load
- average number of reversed bending stresses

#### Non-rotating special rope

##### SE-znk - 1960 N/mm<sup>2</sup>

##### Standard rope for electric winches, non-rotating spiral strand rope 3 - 13 mm Ø

Galvanized

- balanced characteristics
- lifting rope for unguided single rope suspension elements
- lifting rope for large lifting heights with multiple rope suspension elements
- not to be used with a swivel
- high strength
- high bending fatigue characteristics

#### Heavy duty winch rope

##### Electric winch rope with plastic-coated steel core in double-parallel type of construction 6 - 30mm Ø

Bright and greased, not non-twisting

- special rope for frequent bending stress reversals and long use
- to be used only with matching rope sheaves and drums
- optimized break loads due to higher fill factor

## INFO

The use of plastic-coated steel wire ropes with lifting equipment is not permitted.

To meet individual requirements we can provide assistance for the selection of length, diameter and type of the rope, as well as a fastening equipment (thimbles, hooks, rope clips, etc.).

## Rope fasteners/rope connections

The safe functioning of the rope drive depends to a large extent on the rope fastenings on the winch and on the load. Rope connections and ropes themselves have to be checked at regular intervals by competent persons. The following rope connections are permissible for use with lifting equipment:

### Non-releasable rope connections

#### Aluminium press-on connection

with thimbles

in combination with safety eye hooks or screw shackles provide a simple and safe means of suspending loads.

#### Splice connections (uncoated)

in combination with thimbles, hooks, etc.

In the most unfavourable situation, splice connections can lead to a reduction in the breaking load of the rope line of up to 40%.

### Releasable rope connections

#### Rope clips

- The end which is not under load must never be fastened to the load-bearing line.
- The length of the unloaded rope end should be at least 20 times the diameter of the rope and not less than 150 mm.
- Clips may no longer be used once the rope has worn by more than 10%.
- Wire rope clamps may not be used for rope connections for lifting equipment, with the exception of fastening equipment which is manufactured for non-recurring, special purposes!

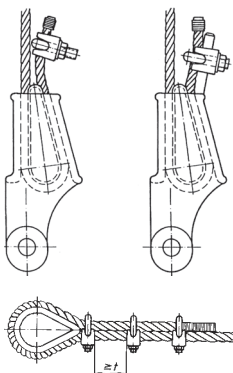
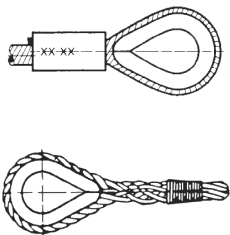

## Handling of ropes – Unwinding



RIGHT

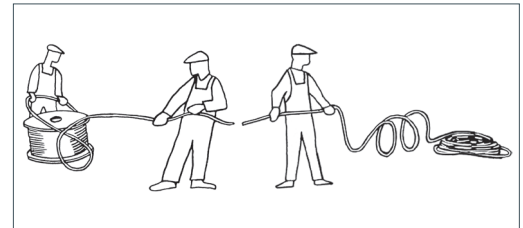

WRONG

## Care of ropes

“Running ropes“ in particular will only offer optimum service lives if they are well lubricated. The use of steel ropes without grease will cause them to wear quickly and the load bearing mechanism will have to be replaced early.

## INFO

Pressed and splice connections may only be produced by specialist firms or rope manufacturers.

## Notes on the installation of winches

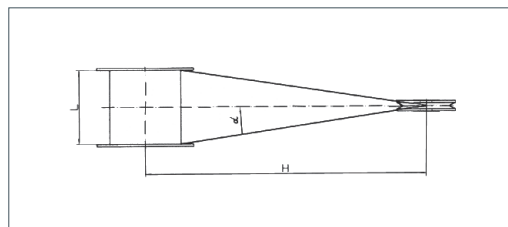

The distance between rope drum and sheave must be selected in a way that the maximum deflection angle for the type of rope used is not exceeded:

**Standard rope – Deflection angle < 3°**  
(Minimum distance = Drum width x 10)

**Special rope - Deflection angle < 1.5°**  
(Minimum distance = Drum width x 20)

- To prevent the wire rope from becoming slack when unloaded it should always have an additional rope weight when used with lifting equipment
- Guided loads must be monitored with a slack rope cut-out.
- To prevent the rope from becoming damaged, steel wire ropes must never be guided
  - over edges
  - over deflection radii which are too small or
  - over rope sheaves with grooves which are too small.
- High dynamic forces can lead to sudden breaks or crashes of the load. It is therefore imperative that loads are never brought to a dead stop (“on block”) and that loads are never allowed to drop into the rope.



## Applications of electric winches

Pfaff-silberblau and Yale winches are versatile tools made to lift, lower, pull or position loads. All winches are characterized by high-quality components and drive motors, irrespective of the design as standard or customized version.

All products are differentiated by long lifetimes and a reliable operational safety.

Capacities between 250 kg up to 7500 kg make them a versatile tool for a great number of applications: general industry, aviation and maritime industries, construction, theatres and studios, distributors, retailing and trade, furniture and department stores as well as passenger elevation.



### Königsgalerie Duisburg (Image top left)

A number of BETA winches are used to provide visitors to the Königsgalerie shopping centre with an attractive spectacle suspended up high.

In continuous operation, the individual segments of a crown are moved so as to form the impression of a complete crown at regular intervals following various lifting paths.

### Tbilisi Centre of Music and Culture (Image left)

Thanks to the immense load of three redundant DELTA theatre winches, a heavy sound element weighing approx. 35t is moved above the heads of the audience. Two redundantly arranged gear motors with a brake on each winch are also used to guarantee maximum safety.



### Flood defence in Dresden

Ready for action at all times – this is the most important feature of the BETA traversing winch, which, in an emergency in Dresden, ensures that a flood defence barrier is pulled across the road in good time, thus protecting the city against flood waters from the river Elbe.



## Electric construction winch model EBW 200

### Capacity 200 kg

For easy and quick lifting and lowering of loads on construction sites.

### Features

- Extending slewing frame and clips for tube racks up to max. 45 mm, quickly ready for use.
- Operating cable (length: 1 m) and push-button pendant control with emergency stop.
- Standard operating voltage: 230V, 1-phase, 50Hz



## INFO

Pfaff winches are not designed for passenger elevation applications and must not be used for this purpose.

### Technical data model EBW 200

Model	Art.-No.	Capacity kg	Lifting height m	Lifting speed m/min	Weight without rope kg
EBW 200	031100030	200	25	19.2	48.5



## Electric winch model RPE

### Capacity 250 - 1000kg

Winches series RPE and RPA are designed explicitly for performance, efficiency and safety and offer many advantages and options. RPE's and RPA's extremely compact, practical cube design and universal rope lead-offs allow individual applications in almost any position and make them powerful aids for lifting and pulling loads.

The winches are designed to DIN 15020, classification 1 Bm/M3, safety regulation DGUV Vorschrift 52 (BGVD8) and, of course, the EC machinery directives.

Every winch is factory tested with overload.

The units are supplied with a test certificate showing the unit's serial-no. and an operating instructions manual which contains a manufacturer's declaration.

### Features

- Compact dimensions due to internal brake motor.
- Voltage 400V/230V, 3-phase, 50Hz, protected to IP54, insulation class F.
- Adjustable slip clutch to protect the winch from overloading standard for model RPE 10-6.
- Spur gear transmission with helical first gear ensures smooth motion. Lubricated by grease and can, therefore, be used in any position.
- Spring pressure disc brake incorporated in the motor holds the load secure even in the event of a power failure.
- Plain rope drum standard.
- The rope is secured to the drum in a recess so that the rope can be wound onto the drum in several layers without damage.
- Direct control or 42V low voltage control (incl. push-button with emergency-stop and 2m control cable).



Rope attachment

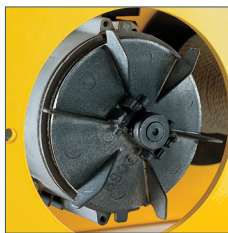

Spring pressure disc brake

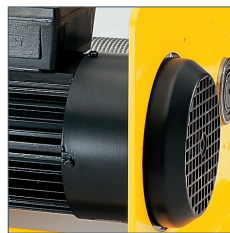

Brake motor

## INFO

When selecting the length of the rope please bear in mind that a minimum of 2-3 windings have to remain on the drum.

Yale hoists and trolleys are not designed for passenger elevation applications and must not be used for this purpose.

## Options

- Different drum designs, e.g. extended to accommodate longer rope, machined grooves for exact reeling, with separation web and 2nd rope outlet for working with two ropes.
- Geared limit switches to limit rope motion in both directions (in combination with 42V low voltage control).
- Single-phase A.C. motor 230V, 50Hz, 42V low voltage control.
- Slack rope switch to automatically stop the winch when rope tension eases e.g. when the load touches down (only in combination with low voltage control).
- Frequency converter for stepless speed control.
- Adjustable slip clutch to protect the winch from overloading for models RPE 2-13, RPE 5-6 and RPE 5-12.
- Special design according to DGUV Vorschrift 17 (BGVC1) for theater stage applications available.
- Radio remote control
- Other operating voltages
- Stainless brake



## INFO

Special design for wind energy as well as customised constructions on request!

Also available as zinc-plated version on request!



Single-phase A.C. motor



Geared limit switches



Gearbox with slip clutch



Different drum designs



## Technical data model RPE

Model	EAN-No. 4025092*	Capacity	Lifting speed 1 <sup>st</sup> layer	Lifting speed top layer	Rope diameter	Motor	ED	Useable rope length 1 <sup>st</sup> layer	Useable rope length top layer	Weight without rope
		kg	m/min	m/min	mm	kW	%	m	m	kg
<b>RPE 2-13</b>	*071796	250	10.2	13.2	4	0.55	40	11.2	54.5	31.8
<b>RPE 5-6</b>	*071857	500	4.6	6.6	6	0.55	40	7.0	38.8	32.8
<b>RPE 5-12</b>	*071918	500	8.7	12.6	6	1.1	40	11.0	55.4	41.0
<b>RPE 9-6</b>	*071956	990	5.1	6.5	8	1.1	40	10.2	37.4	76.0
<b>RPE 10-6<sup>1</sup></b>	*072014	1000	5.1	6.5	8	1.1	40	10.2	37.4	76.9

<sup>1</sup>With slip clutch

## Plain drum (longer useable rope length)

Model	Capacity top layer kg	Drum size	Useable rope length max. m
<b>RPE 2-13 L</b>	250	2	80
<b>RPE 5-6 L</b>	500	2	58
<b>RPE 9-6/10-6 L</b>	990/1000	2	56
<b>RPE 2-13 XL</b>	250	3	200
<b>RPE 5-6 XL</b>	500	3	140
<b>RPE 5-12 XL</b>	500	3	140
<b>RPE 9-6/10-6 XL</b>	990/1000	3	100

## Grooved drum (recommended for single layer operation)

Model	Capacity top layer kg	Drum size	Useable rope length 1 <sup>st</sup> layer m	Useable rope length max. m
<b>RPE 2-13 R</b>	250	1	8.8	43
<b>RPE 5-6 R</b>	500	1	6.2	33
<b>RPE 9-6/10-6 R</b>	990/1000	1	8.2	30
<b>RPE 2-13 LR</b>	250	2	13.3	64
<b>RPE 5-6 LR</b>	500	2	9.5	49
<b>RPE 5-12 LR</b>	500	2	9.5	49
<b>RPE 9-6/10-6 LR</b>	990/1000	2	12.9	47
<b>RPE 2-13 XLR</b>	250	3	35.3	165
<b>RPE 5-6 XLR</b>	500	3	25.7	128
<b>RPE 5-12 XLR</b>	500	3	25.7	128
<b>RPE 9-6/10-6 XLR</b>	990/1000	3	25.2	89



## INFO

When selecting the length of the rope please bear in mind that a minimum of 2-3 windings have to remain on the drum.

Yale hoists and trolleys are not designed for passenger elevation applications and must not be used for this purpose.

Winches with drums for longer useable rope lengths have partly other dimensions than those shown on page 95.

## Dimensions model RPE (400V direct control, standard drum)

Model	RPE 2-13	RPE 5-6	RPE 5-12	RPE 9-6	RPE 10-6
A, mm	405	405	405	525	525
B, mm	375	375	375	485	485
C, mm	18	18	18	25	25
DTR, mm	76	76	76	108	108
Dmax, mm	104	118	118	148	148
DA, mm	150	150	150	180	180
E, mm	338	338	428	450	450
F, mm	210	210	300	270	270
G, mm	260	260	350	345	345
H, mm	290	290	380	380	380
I, mm	11	11	11	13	13
K, mm	250	250	250	340	340
L, mm	125	125	125	170	170
M, mm	6	6	6	10	10
N, mm	33	33	33	47.5	47.5
O, mm	194	194	284	250	250
P, mm	19	19	19	24	24
Q, mm	13	13	13	19	19
R, mm	125	125	125	170	170
S, mm	4	6	6	8	8
$\alpha 1, ^\circ$	130	130	130	145	145
$\alpha 2, ^\circ$	110	110	110	125	125
$\alpha 3, ^\circ$	40	40	40	50	50
$\beta 1, ^\circ$	150	150	150	155	155
$\beta 2, ^\circ$	90	90	90	100	100
$\beta 3, ^\circ$	80	80	80	83	83

Dimensions for s with optional features are available on request!

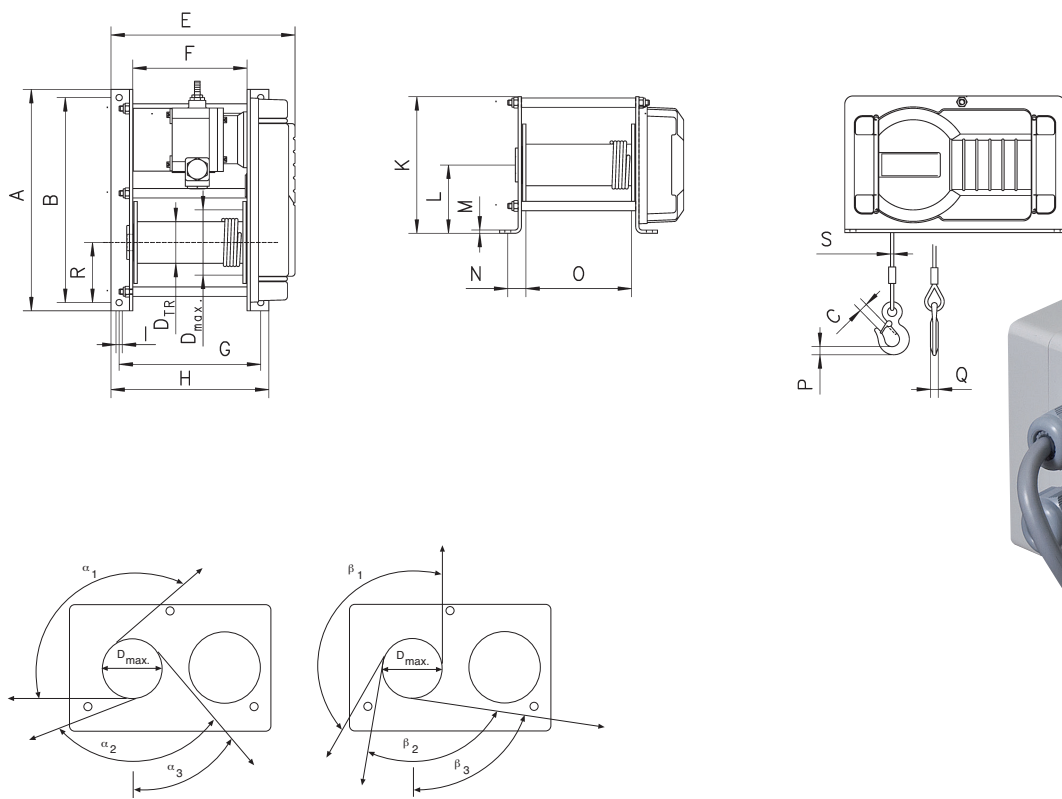

Rope lead-offs for electric winch RPE



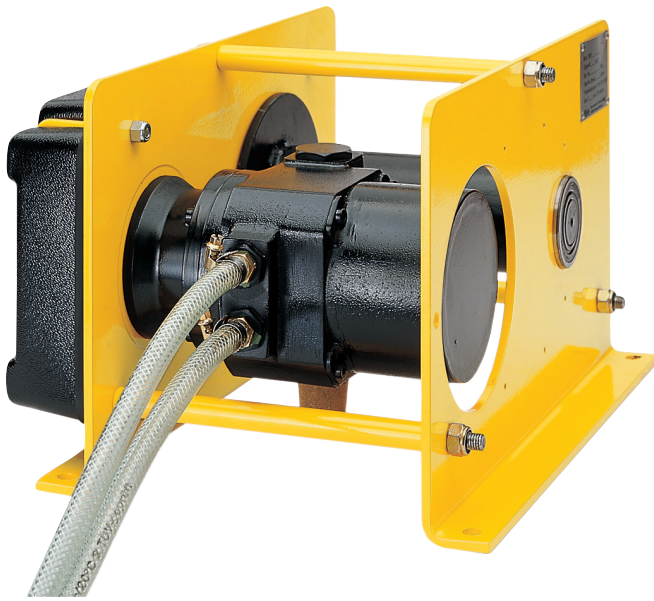

## Pneumatic winch model RPA

### Capacity 250 - 500 kg

The conception is in accordance with the design of the model RPE.

With 100% duty rating and an unlimited number of starts the model RPA is suitable for heavy duty applications. It is insusceptible to contamination, humidity and aggressive mediums from the outside.

### Features

- Robust rotating piston motor with high starting torque, designed for operating pressures 4 to 6 bar.
- Spring pressure disc brake incorporated in the motor holds the load secure even in the event of an air failure.
- Sensitive control by means of direct acting valves in the control switch.

### Options

- Different drum designs, e.g. extended to accommodate longer rope, machined grooves for exact reeling, with separation web and 2nd rope outlet for working with two ropes.
- Control including 2.5m hose and air coupler.
- Maintenance unit for main air supply pipe (pressure regulator, manometer, lubricator and support).



Rope attachment

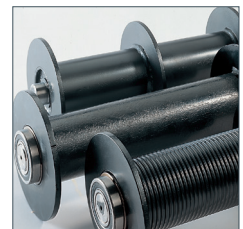

Different drum designs

## INFO

To ensure faultless operation the compressed air supply must be filtered and oiled!

Available in corrosion proof version on request!

Yale hoists and trolleys are not designed for passenger elevation applications and must not be used for this purpose.

## Technical data model RPA

Model	EAN-No. 4025092*	Capacity  daN	Lifting speed with rated load <sup>1</sup> m/min	Lifting speed without load <sup>1</sup> m/min	Lowering speed with rated load <sup>1</sup> m/min	Rope diameter  mm	Motor  kW	Useable rope length top layer  m	Weight without rope  kg
<b>RPA 2-13</b>	*072397	250	12.5	20	22	4	0.55	54.5	36.7
<b>RPA 5-6</b>	*072458	500	6.2	10	11	6	0.55	38.8	36.7

<sup>1</sup> Values in the top layer for 6 bar, air consumption 0.75 m<sup>3</sup>/min

## Dimensions model RPA

Model	RPA 2-13	RPA 5-6
A, mm	405	405
B, mm	375	375
C, mm	18	18
DTR, mm	76	76
Dmax, mm	104	118
DA, mm	150	150
E, mm	336	336
F, mm	210	210
G, mm	260	260
H, mm	290	290
I, mm	11	11
K, mm	250	250
L, mm	125	125
M, mm	6	6
N, mm	33	33
O, mm	194	194
P, mm	19	19
Q, mm	13	13
R, mm	125	125
S, mm	4	6
$\alpha 1, ^\circ$	130	130
$\alpha 2, ^\circ$	90	90
$\alpha 3, ^\circ$	20	20
$\beta 1, ^\circ$	150	150
$\beta 2, ^\circ$	70	70
$\beta 3, ^\circ$	60	60

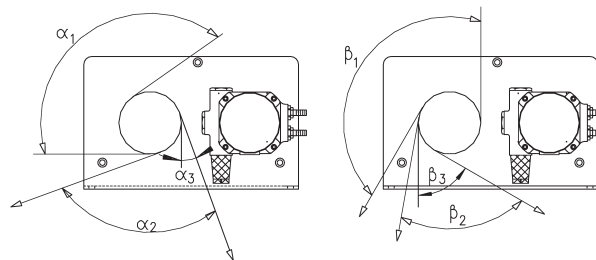

Rope lead-offs for pneumatic rope winch RPA

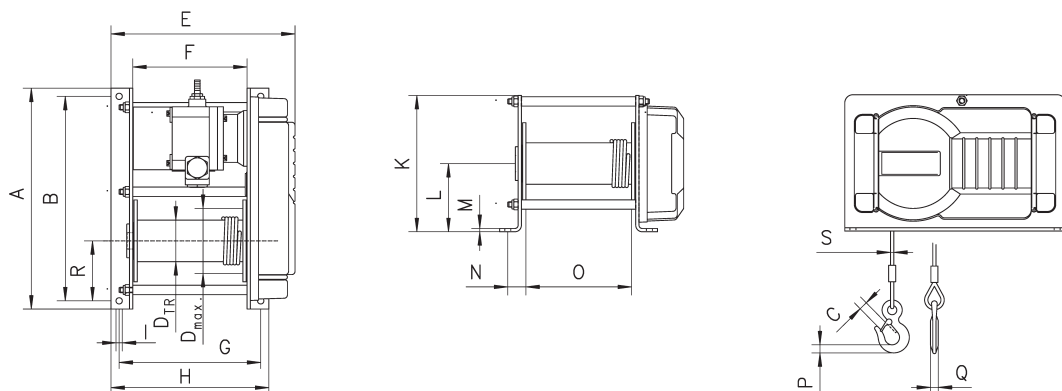

## INFO

When selecting the length of the rope please bear in mind that a minimum of 2-3 windings have to remain on the drum.



## Electric winch model BETA SL

### Capacity 250 - 2000 kg

Electric winches of the BETA SL range are used for lifting, towing and positioning of loads. The proven technology and specified equipment features make the winch the ideal product for standard applications.

#### Features

- The electrically released spring pressure disc brake safely holds the load also in the event of a power failure.
- Powerful three-phase AC drives for multi-range voltage 380 - 420V, 50Hz or 440 - 460V, 60Hz. Motor type of enclosure IP 55, duty factor 40% ED.
- Electronic overload protection from 1000kg lifting load as standard.
- The maintenance-free, oil lubricated gearbox has quiet running characteristics due to milled and ground gears with helical teeth.
- Standard rope drum of grooved design, with large rope capacity.
- Variable rope lead-in.
- Contactor control (incl. gear limit switch).
- Complies DGUV Vorschrift 54 (BGVD8).

*Also available at short notice with the following options:*



Optional: Frequency converter  
(For infinitely variable speed regulation)

- **Rope pressure roll**  
Supports the tidy coiling of the rope, especially with high lifting heights.
- **Slack rope switch**  
Prevents unwanted uncoiling if the wire rope is not under load.
- **Control switch with 3m control cable**  
Greater freedom of movement for the user, better view of the working area of the wire rope winch.
- **Frequency converter (SL 1 - SL 3)**  
Infinitely variable rope speed controlled via potentiometer, control range 20-87Hz (SL 3 = 20-50 Hz). The frequency converter allows loads to be moved gently and sensitively.



## Technical data model BETA SL

EAN-No. 4053981** 4050939***	Size	Capacity 1 <sup>st</sup> layer kg	Lifting speed 1 <sup>st</sup> layer m/min	Rope diameter <sup>3</sup> mm	Motor kW	Classification FEM/ISO	Useable rope length	
							1 <sup>st</sup> layer m/min	top layer m/min
**011912	SL0	250	2.5	4	0.25	1Bm/M3	7	46.7
***050498	SL0	250	4.7	4	0.37	1Bm/M3	7	46.7
**011929	SL1	500	6.8	6	0.75	1Am/M4	6.7	48.9
**011936	SL1	630	6.8	6	0.75	1Bm/M3	6.7	48.9
**011943	SL2	980	6.0	9	1.1	1Am/M4	11	77.5
**011950	SL2	1250	6.0	9	1.1	1Am/M4	11	77.5
**011967	SL3	2000	6.8	12	2.2	1Bm/M3	10	74.5

<sup>3</sup>recommended rope: DIN 3069 FE-znk 1960 sZ-spa

## Dimensions model BETA SL

EAN-No.	**011912	***050498	**011929	**011936	**011943	**011950	**011967
A, mm	185	185	215	215	270	270	320
B, mm	170	170	300	300	400	400	510
Ø C, mm	12	12	13.5	13.5	18	18	22
F, mm	389	389	740	750	920	930	1070
G, mm	200	200	340	340	465	465	570
H, mm	241	241	340	345	475	480	614
K, mm	432	-	-	-	-	-	-
L, mm	180	180	200	200	250	250	300
Ø M, mm	64	64	86	86	175	175	175

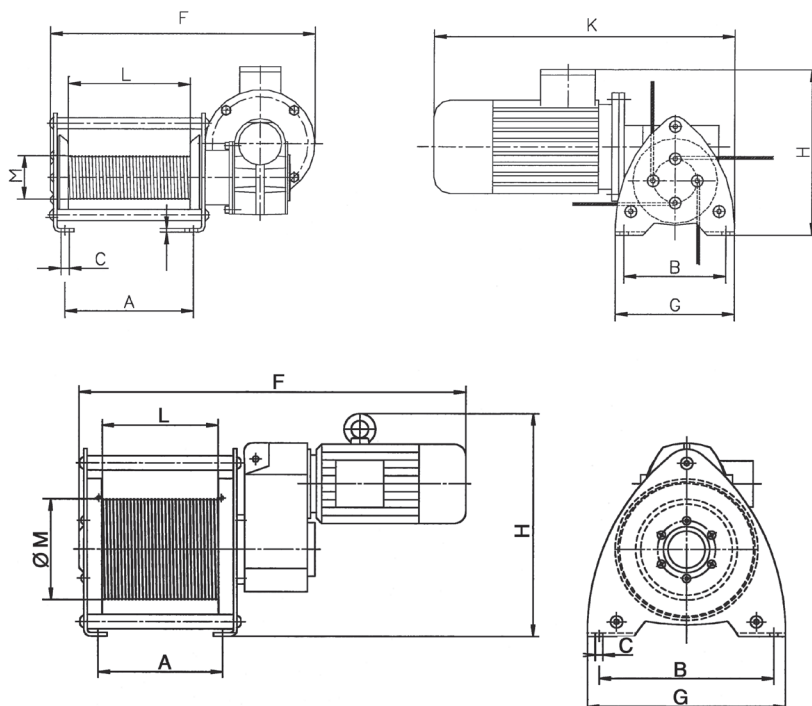

## INFO

Additional options and an adaptation for special applications are offered exclusively for model BETA EL (see page 100).

Pfaff winches are not designed for passenger elevation applications and must not be used for this purpose.



*Application oriented  
winch solutions*

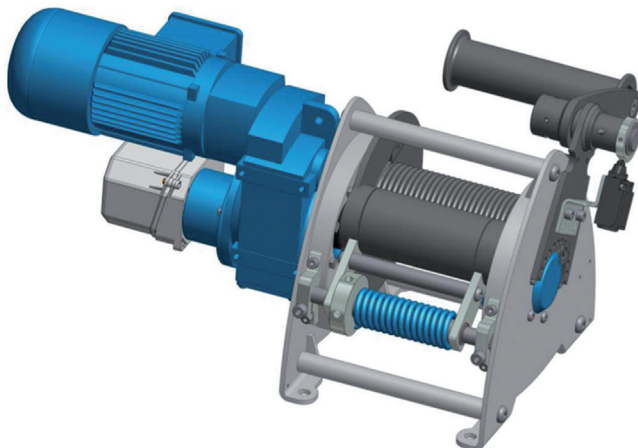
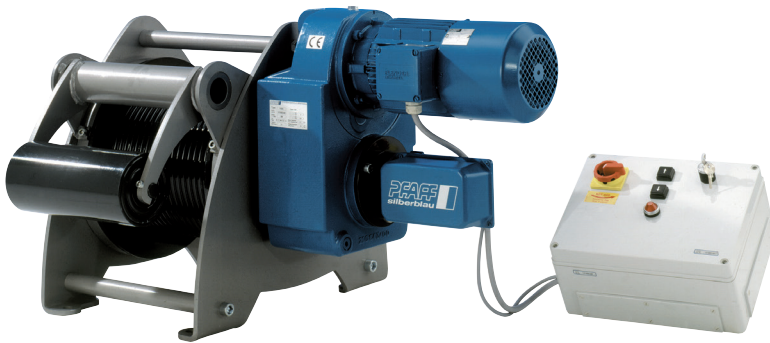

## Electric winch model BETA EL

### Capacity 320 - 7500kg

The BETA EL electric wire rope winches are used for lifting, pulling and positioning loads under difficult conditions. All the models are constructed on a modular basis and comprise various options for maximum flexibility in putting together an individual solution.

The application of high-quality components and gear motors ensure safety and a long service life.

- The electrically released spring pressure disc brake safely holds the load also in the event of a power failure.
- Powerful three-phase AC drives for multi-range voltage 380 - 420V, 50Hz oder 440 - 460V, 60Hz. Motor type of enclosure IP55, duty factor 40% ED.
- Electronic overload protection from 1000kg lifting load as standard.
- The maintenance-free, oil lubricated gearbox has quiet running characteristics due to milled and ground gears with helical teeth.
- Variable rope lead-in due to two rope attachment points (left and right).
- Increased operating safety due to 42V contactor control.

### Equipment options

- Various drum designs e.g. extended for a larger rope capacity, special rope drums for operation with several ropes.
- Rope pressure rollers to prevent the unloaded rope from jumping off the drum.
- Adjustable gear limit switch for limiting the rope path in both directions.
- Slack rope switch for automatically stopping the winch when the rope tension eases or when the load is set down.
- Frequency inverter for infinitely variable speed control.
- External operation via cable/radio
- Other operating voltages
- Other motor protection
- Absolute or incremental encoder
- Special preservation
- In compliance with DGUV Vorschrift 17 (BGVC1) also available for application on stages and in studios.



Available in explosion proof version (please see page 464).

## Sheave block for rope guidance, equipped with ball bearings model DSRB S

### Technical data model DSRB S

Model	EAN-No. 4025092* 4050939***	Classification FEM/ISO	Pulling force in kg at deflection 90°	Pulling force in kg at deflection 180°	Rope diameter mm
DSRB S 90/4	***066062	2m/M5	700	500	4
DSRB S 145/5	***065812	4m/M6	1100	800	5
DSRB S 145/6	*994811	2m/M5	1100	800	6
DSRB S 185/8	***065843	2m/M5	2300	1630	8
DSRB S 185/9	***065850	1Am/M4	2300	1630	9
DSRB S 270/12	***065980	2m/M5	2500	1800	12
DSRB S 325/14	***066055	2m/M5	4500	3200	14
DSRB S 400/16	***066130	3m/M6	5000	3800	16
DSRB S 400/18	***065720	2m/M5	5000	3800	18
DSRB S 490/20	***065751	3m/M6	8000	6000	20



### Dimensions model DSRB S

Model	DSRB S 90/4	DSRB S 145/5	DSRB S 145/6	DSRB S 185/8	DSRB S 185/9	DSRB S 270/12	DSRB S 325/14	DSRB S 400/16	DSRB S 400/18	DSRB S 490/20
EAN-No.	***066062	***065812	*994811	***065843	***065850	***065980	***066055	***066130	***065720	***065751
B, mm	85	125	125	138	138	191	260	302	302	313
C, mm	90	160	160	195	195	290	350	430	430	580
Ø D, mm	90	145	145	185	185	270	325	400	400	490
Ø D1, mm	20	25	25	30	30	40	50	50	50	65
Ø Dm, mm	80	125	125	160	162	246	297	368	364	450
E, mm	62	88	88	106	106	138	180	212	212	220
H, mm	134	224	224	273	273	407	490	612	612	694
K, mm	65	110	110	135	135	202	242	310	310	340
L, mm	120	200	200	245	245	360	440	530	530	650
Ø M/M1, mm	9/9	11.5/13	11.5/13	13.5/15	13.5/15	18/20	22/25	26/30	26/30	34/40
S, mm	4	6	6	8	8	10	12	15	15	16

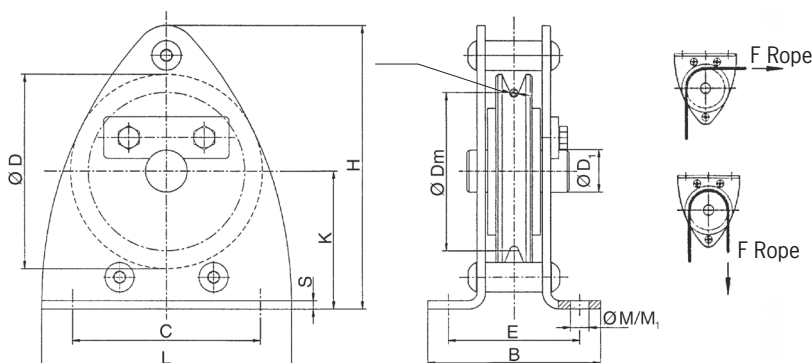

Available in explosion proof version  
(please see page 465).

*Mobile  
endless winch  
up to 300 kg!*



## Options

- Radio remote control with high range.
- Other operating voltages on request.
- Non-rotating steel wire ropes.
- Manual and electric trolleys.
- Frequency converter
- Transport and carrying frames for various applications.

## Endless winch, mobile model YaleMtrac

*New!*

### Capacity 100 - 300 kg

The new compact and light weight mobile Yale-Endless winch, model YaleMtrac combines modern industry design with technical innovation. During the development stage, focus was set on simple and safe operation for mobile applications. The winch is capable of lifting loads up to 300 kg over long distances at high speed.

The highlight of the YaleMtrac winch is the increased efficiency as it can be operated bi-directionally.

The Yale Mtrac winch can lift, lower and pull loads at rated capacity in either direction. Depending on the application unnecessary waiting time to return the load hook to its start position may be eliminated.

A wide range of ropes and accessories (eye sling hooks, self-locking hooks, shackles ) ensure that YaleMtrac winch can be used in many different applications.

### Features

- The robust, precisely machined housing of die-cast aluminium with impact resistant plastic cover ensures a low deadweight and outstanding rigidity.
- The externally adjustable slip clutch is designed to guarantee a permanent connection between the load and the brake.
- High speed versions available to increase efficiency for high lifts.
- Easy access to all wearing parts due to modular design.
- The standard, oil bath lubricated and case hardened gearbox has a helical gearing for particularly smooth running and enhanced lifetime.
- Drive sheave made of specially hardened steel to minimize wear of the components.
- The standard version is supplied with an eye sling hook with safety latch.
- Multiple fixing points in the housing allow the YaleMtrac to be suspended in various positions.
- Classification: 1Bm/M3 acc. to FEM/ISO.
- Motor protected to IP55 (acc. to VDE 0530), against ingress of dust and water jets.
- Standard operating voltage: Euro-voltage: 400V, 3-phase, 50Hz and 230V, 1-phase, 50Hz.
- Rubber buffers ensure no surface contact damage.
- Push-button pendant control, IP65 against ingress of dust and water jets from all directions.
- Limit switch for upward and downward travel.

## Technical data model YaleMtrac

Model	Capacity kg	Lifting speed m/min	Rope diameter mm	Motor kW	Operating voltage
YMT 1-15	100	15	6.5	0.25	230V/1 Ph/50Hz
YMT 3-5	300	5	6.5	0.25	230V/1 Ph/50Hz
YMTF 0,6-30	66	30/7.5	6.5	0.37	400V/3 Ph/50Hz
YMT 1-30	100	30	6.5	0.55	400V/3 Ph/50Hz
YMTF 2-10	200	10/2.5	6.5	0.37	400V/3 Ph/50Hz
YMT 3-10	300	10	6.5	0.55	400V/3 Ph/50Hz

### Dimensions

A, mm	385
A1, mm	287
A2, mm	272
A3, mm	221
A4, mm	119
B, mm	22
C, mm	29
D, mm	19
E, mm	202
E1, mm	92
F, mm	132
F1, mm	93
F2, mm	147
G, mm	100
G1, mm	84
G2, mm	103
H, mm	201
K, mm	M8
L, mm	426
L1, mm	159

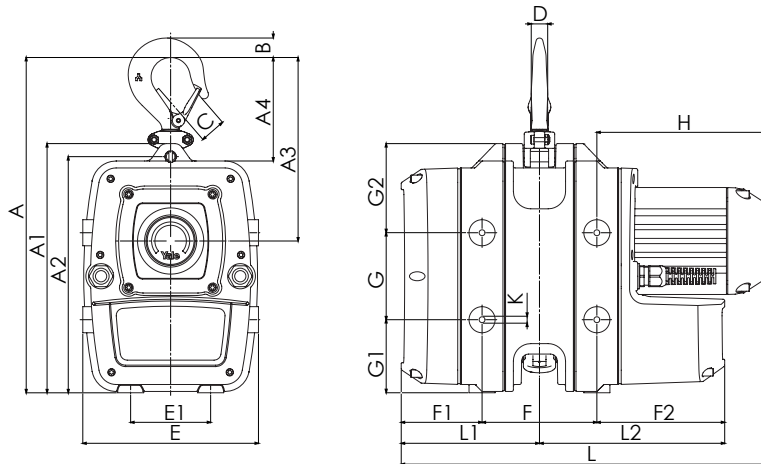

## INFO

Yale hoists and trolleys are not designed for passenger elevation applications and must not be used for this purpose.



### Option:

Equipment based on transport frame and/or ergonomic handles facilitate handling and transport.

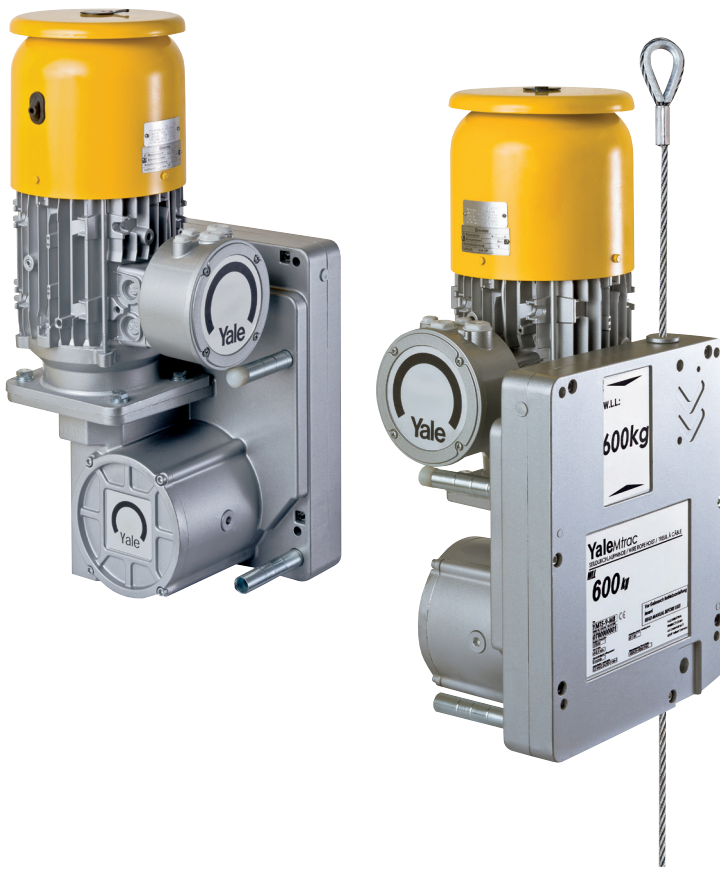

## INFO

Approved for passenger elevation applications in accordance with EN 1808.

### Options

- Other operating voltages
- Radio remote control
- Double control for several winches.
- Limit switch for upward and downward travel.
- Counters for operating hours and number of starts
- Catching devices (overspeed or inclined position tripping, required for passenger elevation applications).
- Adaptor for fitting with shackle.
- Ropes for endless winches and catching device
- Overload protection (included in the scope of supply for passenger elevation winches).
- Storage reel for the unloaded rope.

## Endless winch for the transportation of goods- and personnel model YaleMtrac

With the new YaleMtrac, the rope is driven through the winch without the necessity of having to collect the rope on a reel etc. This enables unlimited lifting heights or traction lengths. Unlike a drum winch, the wire rope always enters the winch at the same place, thus eliminating undesirable hook movement across the drum and ensures rope speed and pulling force remain constant. Endless winches can be used for various applications, wherever loads have to be lifted or pulled, e.g. for the use on waggons, mobile staffolds, or wind power stations.

### Features

- The robust, precisely machined housing of die-cast aluminium ensures a low deadweight and outstanding rigidity. Standardised components feature easy access to all wearing parts.
- Drive sheave and pressure rollers made of specially hardened steel guarantee low wear of the components.
- Limit switch for lifting force as standard (only for winches for passenger elevation).
- The winch can be suspended from a central suspension point by means of a load pin. As an alternative, attachment points in the corners of the housing are available for flexible attachment of the winch with screws or pins.
- Classification  
1 Bm/M3 (1 Cm/M2 for 18m/min) acc. to FEM/ISO.
- All motors protected to IP55 (acc. to VDE 0530) as standard, against ingress of dust and water jets.
- Standard operating voltage: Euro-voltage: 400V, 3-phase, 50Hz alternatively 460V, 3-phase, 60Hz.
- 24V control voltage (except material transport control, stationary application – 42V).
- Phase monitoring (except material transport control, stationary application) for an easy and safe connection to changing power supply.
- Hoist motor with thermal overload protection as standard for increased lifetime.
- Approved for passenger elevation applications in accordance with EN 1808.

## Technical data model YaleMtrac Winches for material transport

Model	EAN-No. 4025092* for stationary application <sup>1</sup>	EAN-No. 4025092* for mobile application <sup>2</sup>	Capacity kg	Lifting speed m/min	Rope diameter mm	Motor kW	Weight for stationary application <sup>1</sup> kg	Weight for mobile application <sup>2</sup> kg
<b>YMT 5-9-M8</b>	*668569	*668644	500	9	8.4	1.1	54	62
<b>YMT 5-18-M8</b>	*668576	*668651	500	18	8.4	2.0	54	62
<b>YMT 6-9-M8</b>	*668583	*668668	600	9	8.4	1.1	55	63
<b>YMT 6-18-M8</b>	*668590	*668675	600	18	8.4	2.0	55	63
<b>YMT 8-9-M8</b>	*668606	*668682	800	9	8.4	1.8	55	63
<b>YMT 8-18-M8</b>	*668613	*668699	800	18	8.4	3.6	56	64
<b>YMTF 8-18-M8</b>	–	–	800	18/9	8.4	2.0/3.6	58	66
<b>YMT 10-9-M9</b>	*668620	*668712	980	9	9.0	1.8	55	63
<b>YMT 10-18-M9</b>	*668637	*668705	980	18	9.0	3.6	56	64
<b>YMTF 10-18-M9</b>	–	–	980	18/9	9.0	2.0/3.6	58	66

<sup>1</sup>incl. control voltage 400V, 3-phase, 50Hz, directly attached to the winch, pendant control with emergency-stop (length of control cable 3m)

<sup>2</sup>incl. control cabinet with integrated CE-connector, pendant control with emergency-stop (length of control cable 3m)

### Contacting control for material transport applications (stationary application)

- Control cabinet (260x124x95mm)
- Protected to IP55 (acc. to EN60 529)
- Temperature range -20°C up to +40°C
- Increased operating safety through 42V control voltage
- Master control relay/emergency-stop contactor as standard for a high degree of safety.
- Easily accessible strip terminal
- Cable entry point by cable sleeves
- Motor connected with control cable



#### Hoist motor & brake

Special motor with classification 1Bm/M3 (1Cm/M2 for 18m/min) according to FEM/ISO 4301-1, protected to IP55.



#### Flexible attachment points

Central load pin suspension or alternatively screws or pins on four corners.

### Control cabinet for material transport applications (mobile application)

- Control cabinet (300x400x150mm)
- Protected to IP55 (acc. to EN60 529)
- Temperature range -20°C up to +40°C
- Increased operating safety through 24V control voltage
- Master control relay/emergency-stop contactor as standard for a high degree of safety.
- Phase-sequence relay for monitoring the direction of rotation
- Control transformer according to EN 61558-2, input and output separately fused.
- Warning buzzer for signalling an overload
- Easily accessible strip terminal
- Cable entry point by screwed cable glands
- Motor connected with connector plug
- Power supply connection with phase-changing switch
- Connection for UP emergency limit switch provided

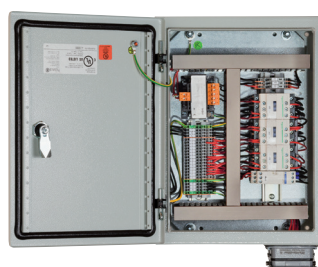
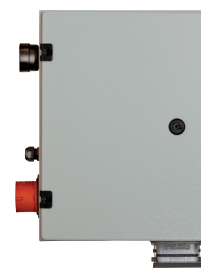

## Technical data model YaleMtrac Winches for passenger elevation according to EN 1808

Model	EAN-No. 4025092*	Capacity kg	Lifting speed m/min	Rope diameter mm	Motor kW	Weight without rope incl. control cabinet kg
YMT 5-9-P8	*668729	500	9	8.4	1.1	72
YMT 5-18-P8	*668736	500	18	8.4	2.0	72
YMT 6-9-P8	*668743	600	9	8.4	1.1	73
YMT 6-18-P8	*668750	600	18	8.4	2.0	73
YMT 8-9-P9	*668767	800	9	9.0	1.8	73
YMT 8-18-P9	*668774	800	18	9.0	3.6	74
YMTF 8-18-P9	*911313	800	18/9	9.0	2.0/3.6	76
YMT 10-9-P10	*668781	1000	9	10.2	1.8	73
YMT 10-18-P10	*668798	1000	18	10.2	3.6	74
YMTF 10-18-P10	*911320	1000	18/9	10.2	2.0/3.6	76

Incl. control cabinet with integrated CE-connector

Incl. pendant control with emergency-stop (length of control cable 3m)

Option: Emergency-stop and UP/DOWN buttons on control cabinet for controlling the winch

Dimensions	
A, mm	266
B, mm	300
Ø C, mm	16.5
Ø D, mm	10.5
E, mm	40
F, mm	57
G, mm	261
H, mm	34
I, mm	375
J, mm	261
K, mm	220
Ø L, mm	180
M, mm	301
N, mm	375
O, mm	599

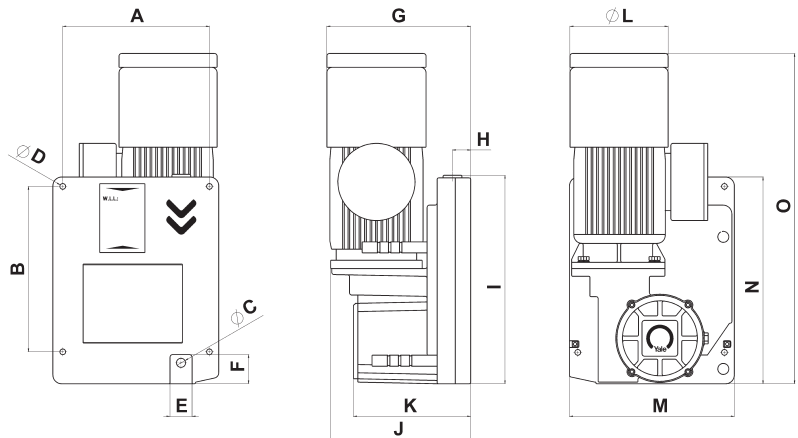

### Options

- Control cabinet for synchronous control of two winches
- Supporting feet and arms for fixing the control cabinet



### Control cabinet for passenger elevation applications

- Control cabinet (300x400x150mm)
- Protected to IP55 (acc. to EN 60 529)
- Temperature range -20°C up to +40°C
- Increased operating safety through 24V control voltage
- Master control relay/emergency-stop contactor as standard for a high degree of safety.
- Phase-sequence relay for monitoring the direction of rotation
- Control transformer according to EN 61558-2, input and output separately fused.
- Warning buzzer for signalling an overload
- Easily accessible strip terminal
- Cable entry point by screwed cable glands
- Motor connected with connector plug
- Power supply connection with phase-changing switch
- Connection for UP emergency limit switch provided



### Safety for passenger elevation

In accordance with the requirements of EN 1808, each winch used for passenger elevation must feature a safety system on an independent safety rope. The product offering provides two different safety catching devices for two common applications.

Both types have been approved for passenger elevation and comply with standard EN 1808

“Safety requirements on suspended access equipment”.

In addition, the catching devices have been approved.



#### Safety hand wheel

In an emergency (power failure), upward movement with released brake is possible by means of the hand wheel included in the supply (standard delivery scope only for winches for passenger elevation application).



#### Safety lowering mechanism

In the event of a power failure, the electro-mechanical brake can be released manually in order to ensure safe and controlled lowering of the load. Safe lowering is guaranteed by the integrated centrifugal force brake.

### Overspeed safety catching device (YOSL)

This overspeed catching device is automatically tripped when the lowering speed exceeds 30m/min (0.5m/s). The integrated clamping jaw mechanism of hardened steel stops the lowering movement of the system within a few centimetres.

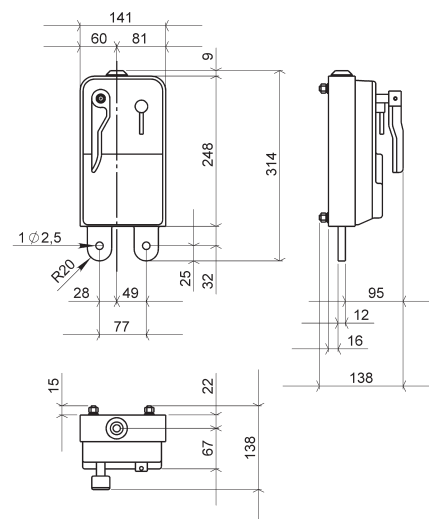

Model	EANNo. 4025092*	Capacity kg	For rope diameter mm
YOSL6-8	*582803	500	8.4
YOSL6-8	*582803	600	8.4
YOSL8-9	*582742	800	9.0
YOSL10-10	*582766	1000	10.2

### Inclined position safety catching device (YISL)

This inclined position catching device is automatically tripped when the angle of the rope or the platform exceeds 5°.

The integrated clamping jaw mechanism holds the rope and immediately stops the movement of the system.

- Robust sheet-steel enclosure
- Clamping mechanism of hardened steel
- Attachment with two screws (M12) or load pins (12mm)

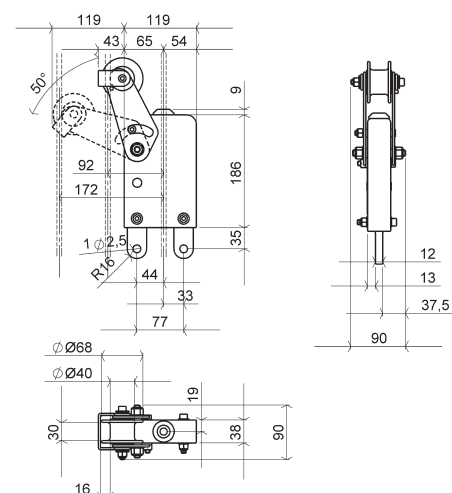

Model	EANNo. 4025092*	Capacity kg	For rope diameter mm
YISL6-8	*582827	500	8.4
YISL6-8	*582827	600	8.4
YISL8-9	*582759	800	9.0
YISL10-10	*582797	1000	10.2